

# 2920306COM Fireplace / TV Stand

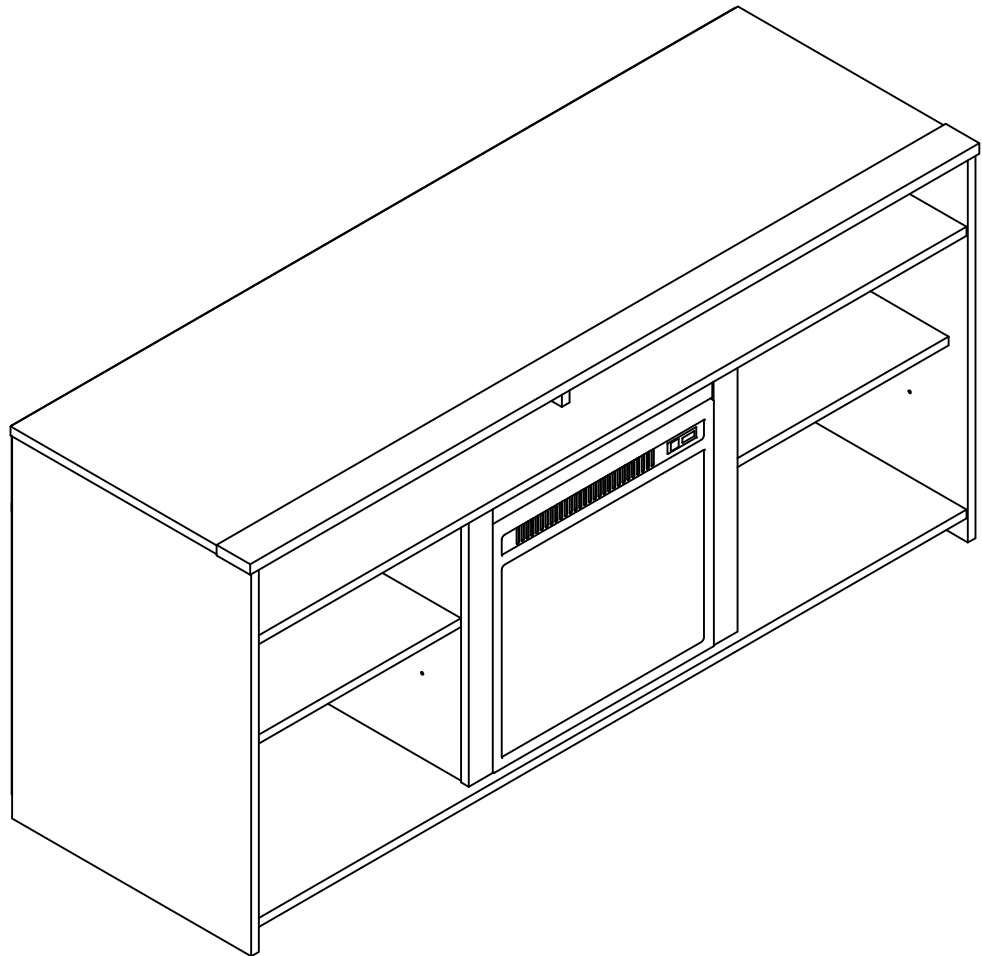

Date of Purchase \_\_\_ / \_\_\_ / \_\_\_  
Lot Number:

B342920306COM0



THIS INSTRUCTION BOOKLET CONTAINS **IMPORTANT** SAFETY INFORMATION. PLEASE READ AND KEEP FOR FUTURE REFERENCE.

### Do Not Return This Product!

Contact our customer service team for help first.

**Call:** 1-800-489-3351 (toll free)

Monday-Friday 9am - 5pm CST

**Visit:** [www.ameriwoodhome.com](http://www.ameriwoodhome.com)



## **WARNING**

- Unit can tip over causing severe injury or death.
- Anchor unit to stud in wall (if instructed to).
- Do Not allow children to climb on unit.
- Put heavy items on lower shelves or drawers.

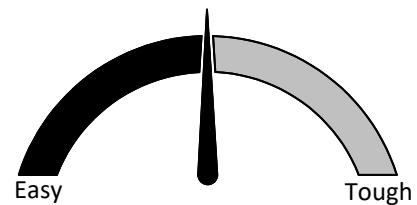

Assembly Difficulty Meter

Follow Ameriwood Home



## Contact Us!

### Do NOT return this product!

Contact our friendly customer service team first for help.



Visit [ameriwoodhome.com](http://ameriwoodhome.com) to view the limited warranty valid in the U.S. and Canada.

Assembly Tips



## Helpful Hints

PEOPLE NEEDED FOR ASSEMBLY: 2

ESTIMATED ASSEMBLY TIME: 1 HOUR

- Open your item in the area you plan to keep it to avoid excessive heavy lifting.
- Identify, sort and count the parts before attempting assembly.
- Compression dowels are lightly tapped in with a hammer.
- Slides are labeled with a **R** (right) and **L** (left) for proper placement.
- Make sure to always face the point on the top of the Cam Lock towards the outer edge.
- Use all the nails provided for the back panel and spread them out equally.
- Back panel must be used to make sure your unit is sturdy.
- Do NOT use harsh chemicals or abrasive cleaners on this item.
- Never push, pull, or drag your furniture.

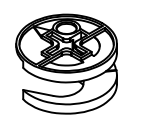

## Before You Start

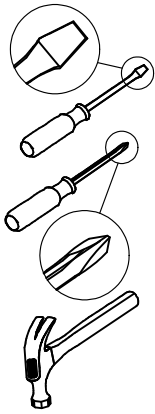
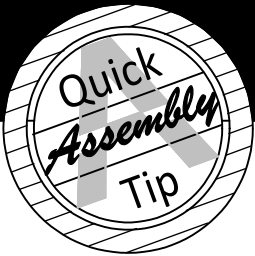

- ✓ Read through each step carefully and follow the proper order
- ✓ Separate and count all your parts and hardware
- ✓ Give yourself enough room for the assembly process
- ✓ Have the following tools: Flat Head Screwdriver, #2 Phillips Head Screwdriver and Hammer
- ✓ Caution: If using a power drill or power screwdriver for screwing, please be aware to slow down and stop when screw is tight. Failure to do so may result in stripping the screw.

## Cam Lock Fastening System

This Cam Lock Fastening System will be used throughout the assembly process.

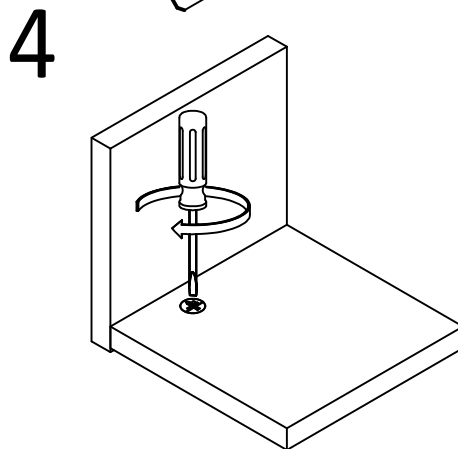
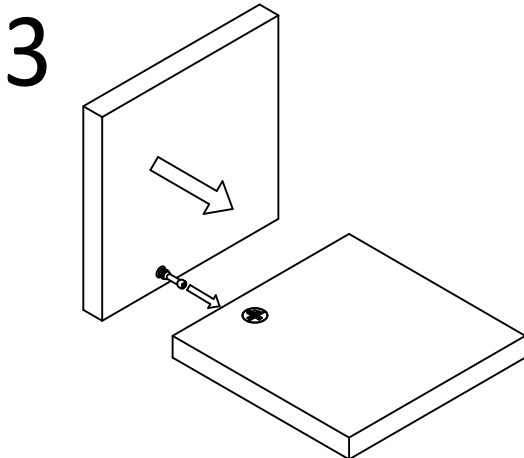
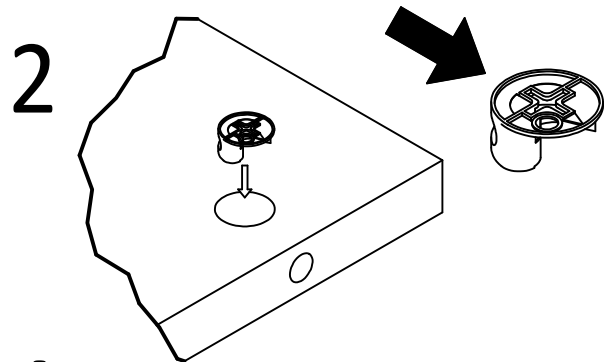
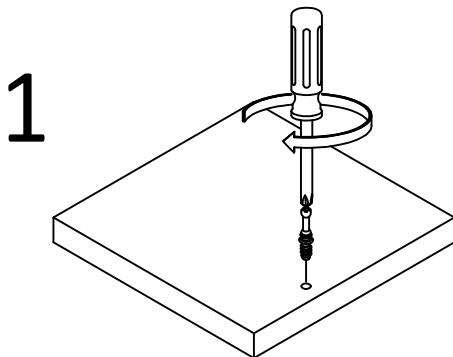

Please Note:

You may need to lightly tap the wood dowels to insert into the holes during your assembly process.

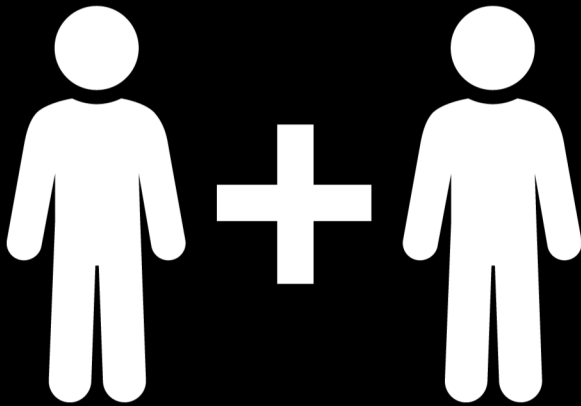
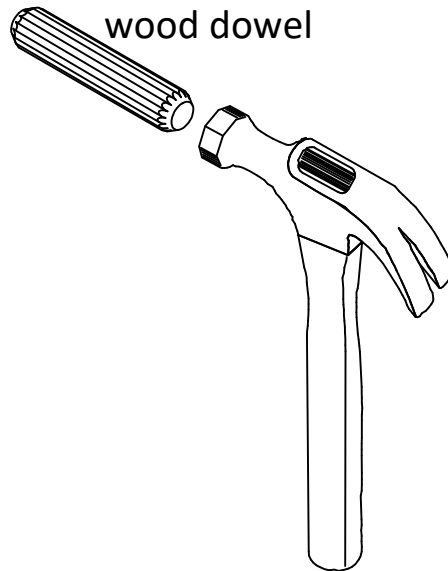

**2 PEOPLE NEEDED FOR ASSEMBLY**

**2 PERSONAS NECESITADAS  
PARA LA ASAMBLEA**

**2 PERSONNES NÉCESSAIRES  
POUR L'ASSEMBLAGE**

**CAUTION:** Failure to use 2 people for assembly could result in unit damage or personal injury.

**PRECAUCIÓN:** Si no se utilizan 2 personas para el ensamblaje, se pueden producir daños en la unidad o lesiones personales.

**ATTENTION:** Échec d'utiliser 2 personnes pour l'assemblage peut causer du dommage au meuble ou causer des blessures.

# Board Identification

Not actual size

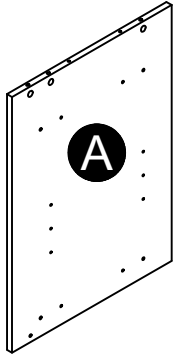

Left Panel  
32920306010

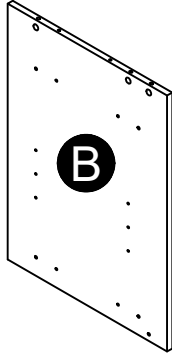

Right Panel  
32920306020

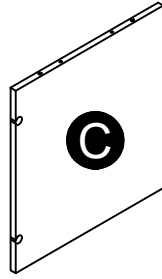

Left Partition  
32920306030

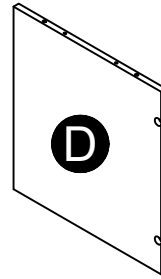

Right Partition  
32920306040

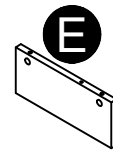

Left Partition  
32920306030

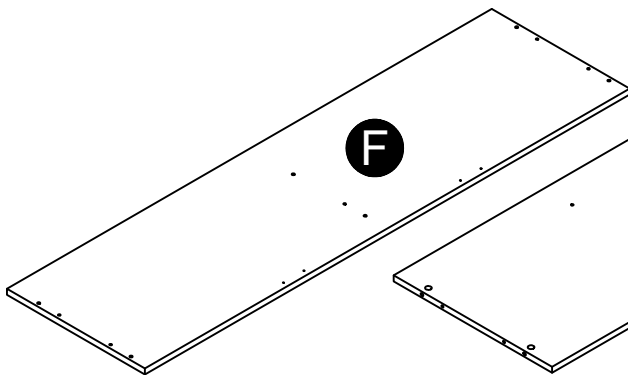

Top  
32920306060

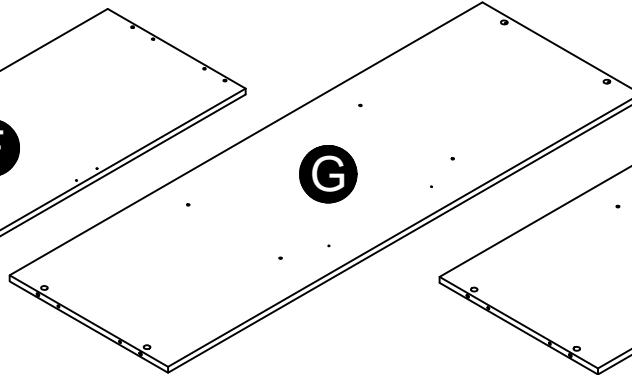

Bottom  
32920306070

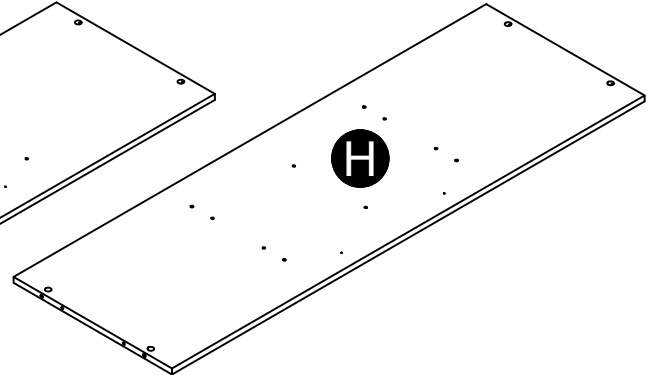

Shelf  
32920306080

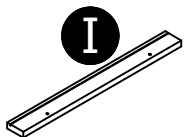

x2  
Vertical Rail  
38620306090

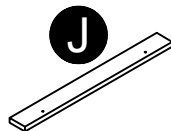

Horizontal Rail  
38620306100

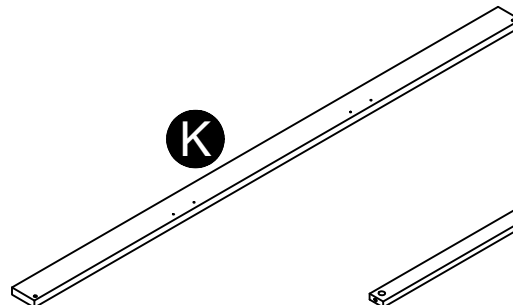

TV Rail  
32920306110

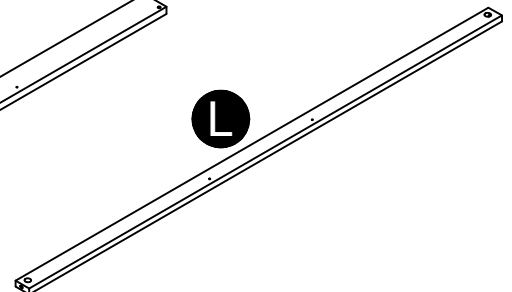

Kick  
32920306120

# Board Identification

Not actual size

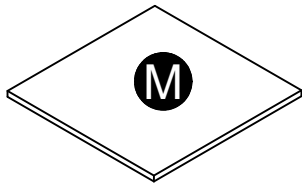

x2  
Adjustable Shelf  
32920306130

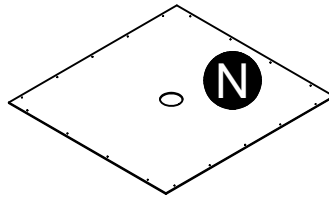

x2  
Back Panel  
K862030600

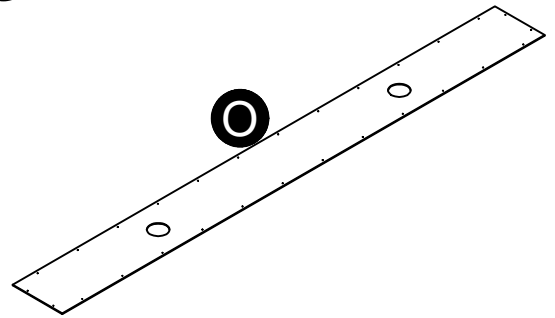

Upper Back Panel  
K292030610

These parts are paperboard construction. They are not made from wood, but are required for the assembly of your unit.

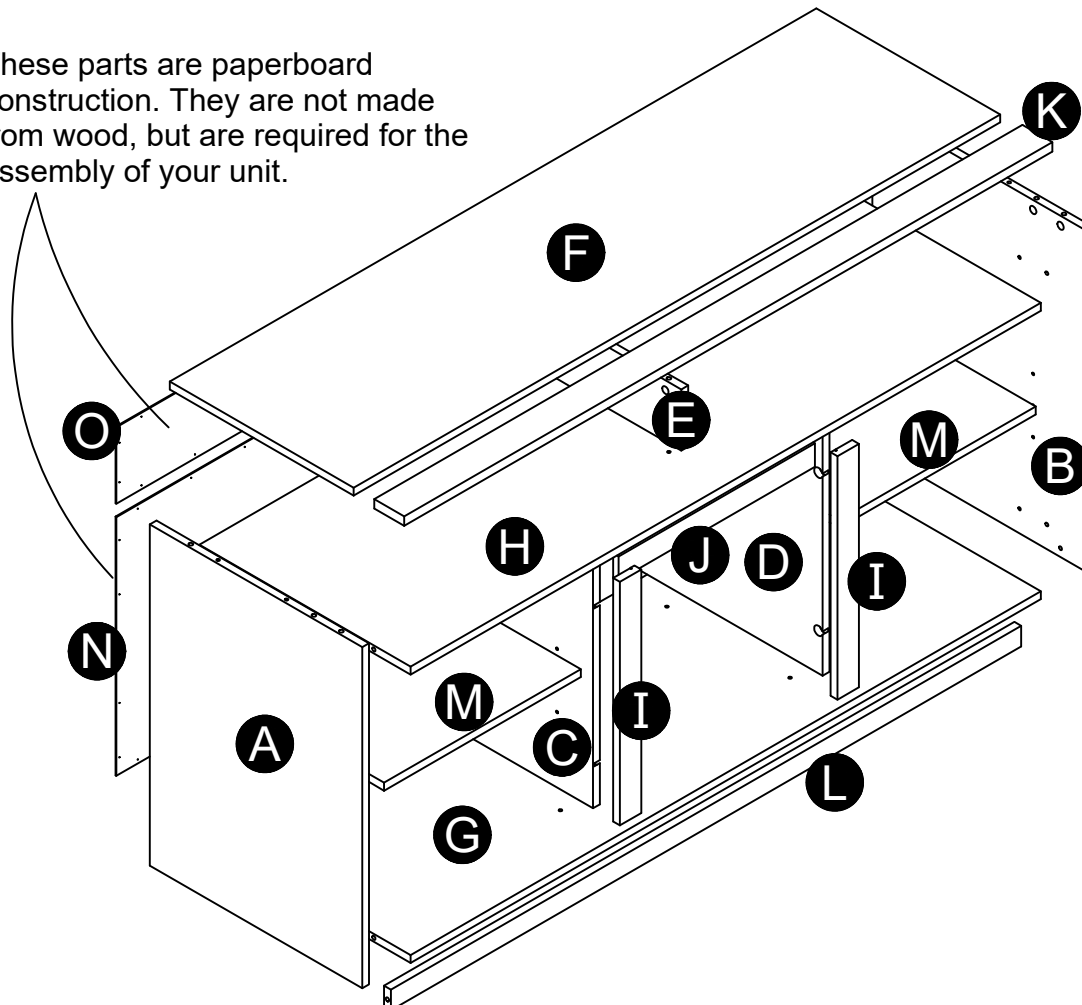

## Part List

Note: Your model may contain extra hardware.

Actual Size

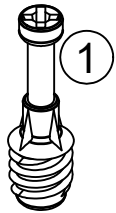

(x22)  
#A22610  
cam bolt

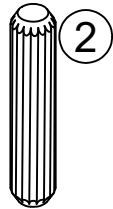

(x17)  
#A21670  
wood dowel

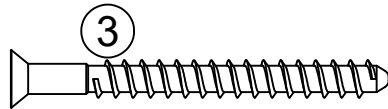

(x6)  
#A23030  
confirmat screw



(x22)  
#A22620  
cam lock



(x8)  
#A80250  
shelf support

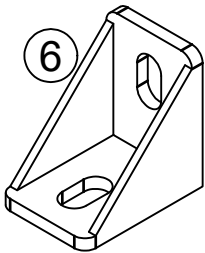

(x4)  
#A53510  
angle bracket

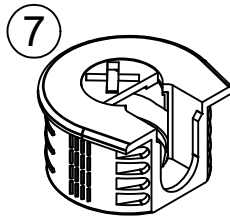

(x4)  
#A22920  
connector



(x4)  
#A22910  
connector bolt

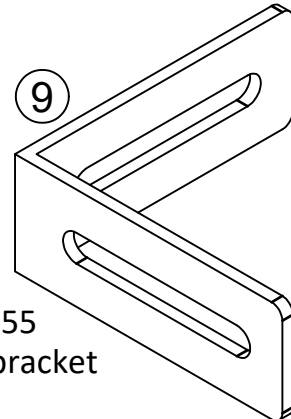

(x1)  
#A53655  
large bracket



(x23)  
#A12120  
7/16" round  
head screw

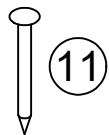

(x64)  
#A21110  
nail

Not Actual Size

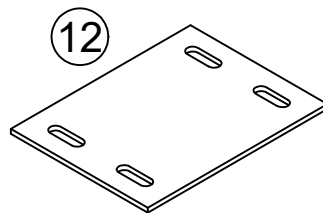

(x2)  
#A54270  
connecting plate

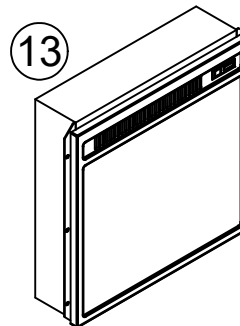

(x1)  
#A95020  
18" fireplace insert

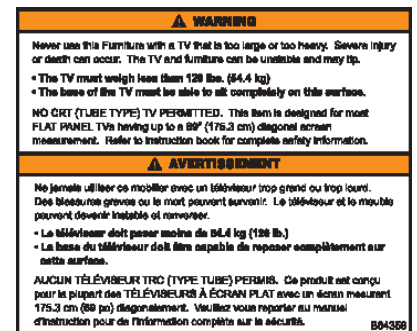

(x1)  
TV Warning Label  
#B64358

## STEP 1

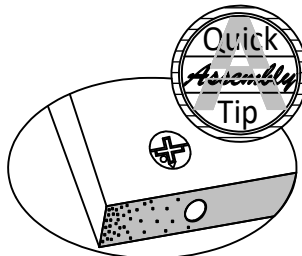
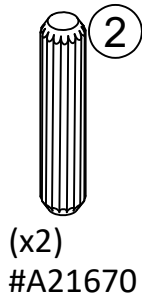
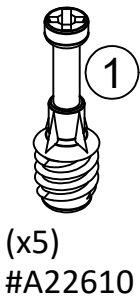
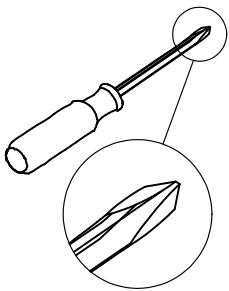

Proper orientation of CAM LOCK

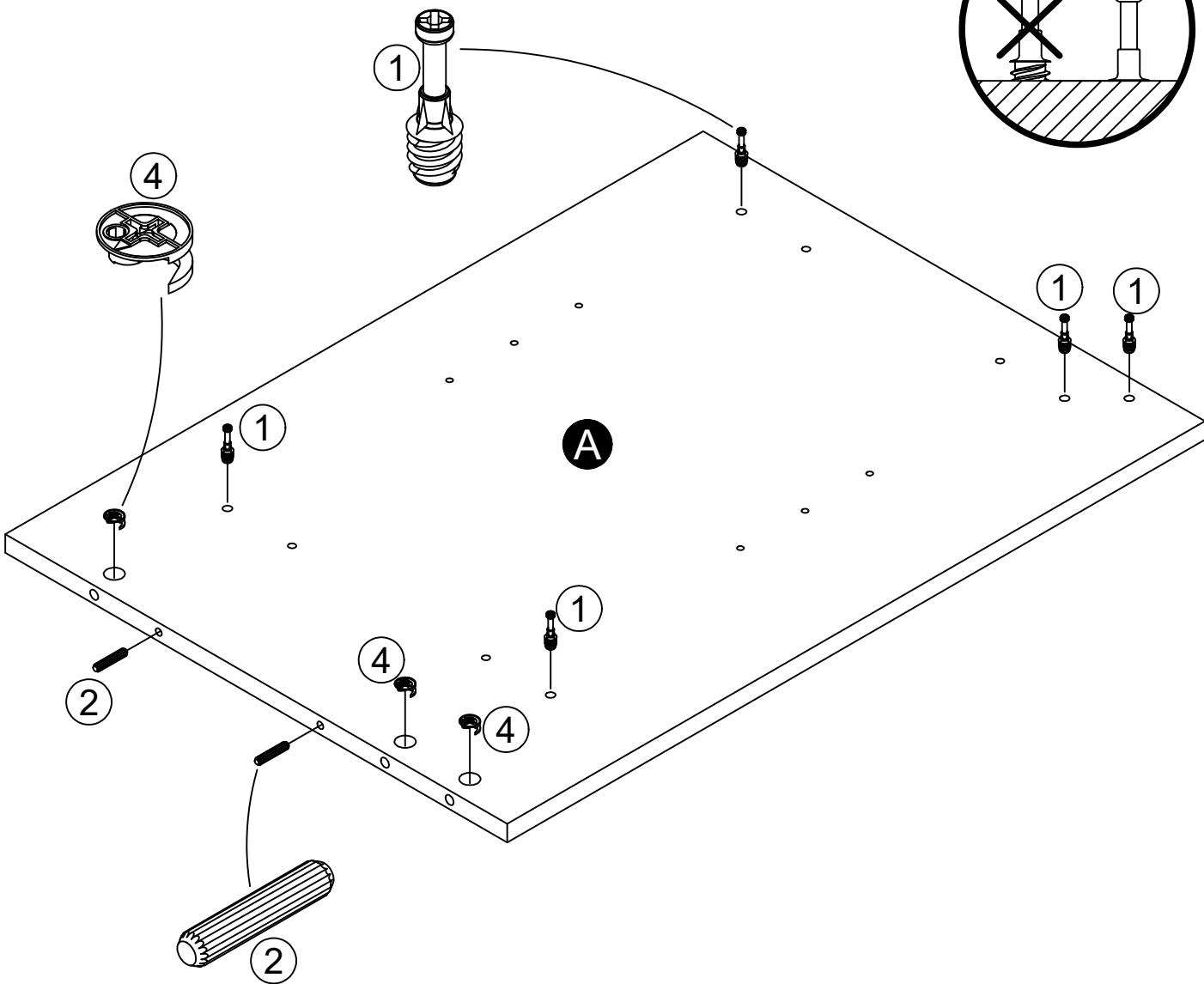
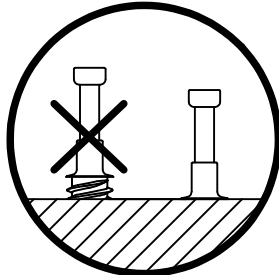



# STEP 2

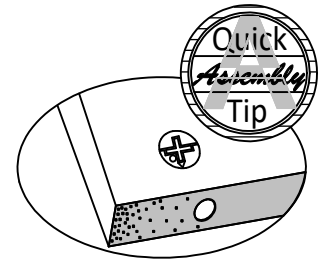
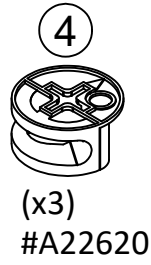
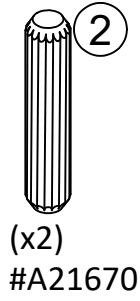
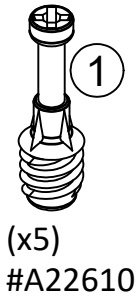
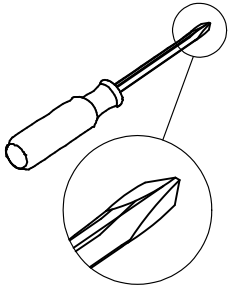

Proper orientation of CAM LOCK

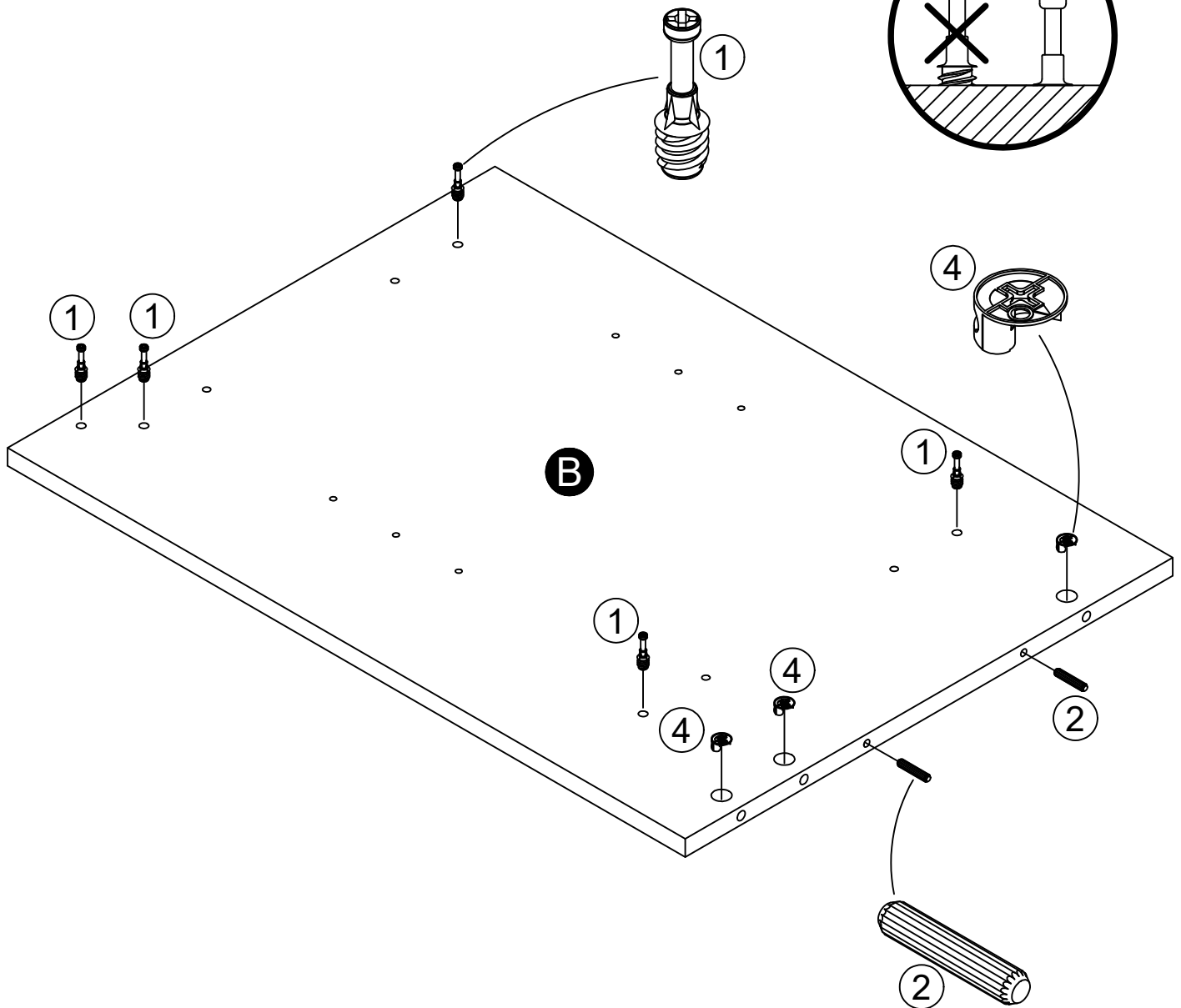
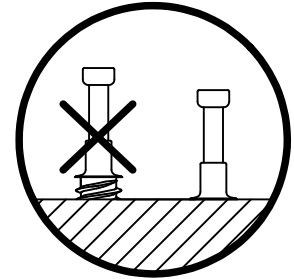

# STEP 3

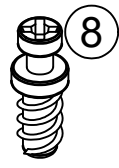
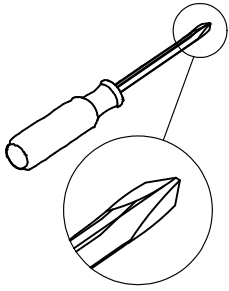

(x4)  
#A22910

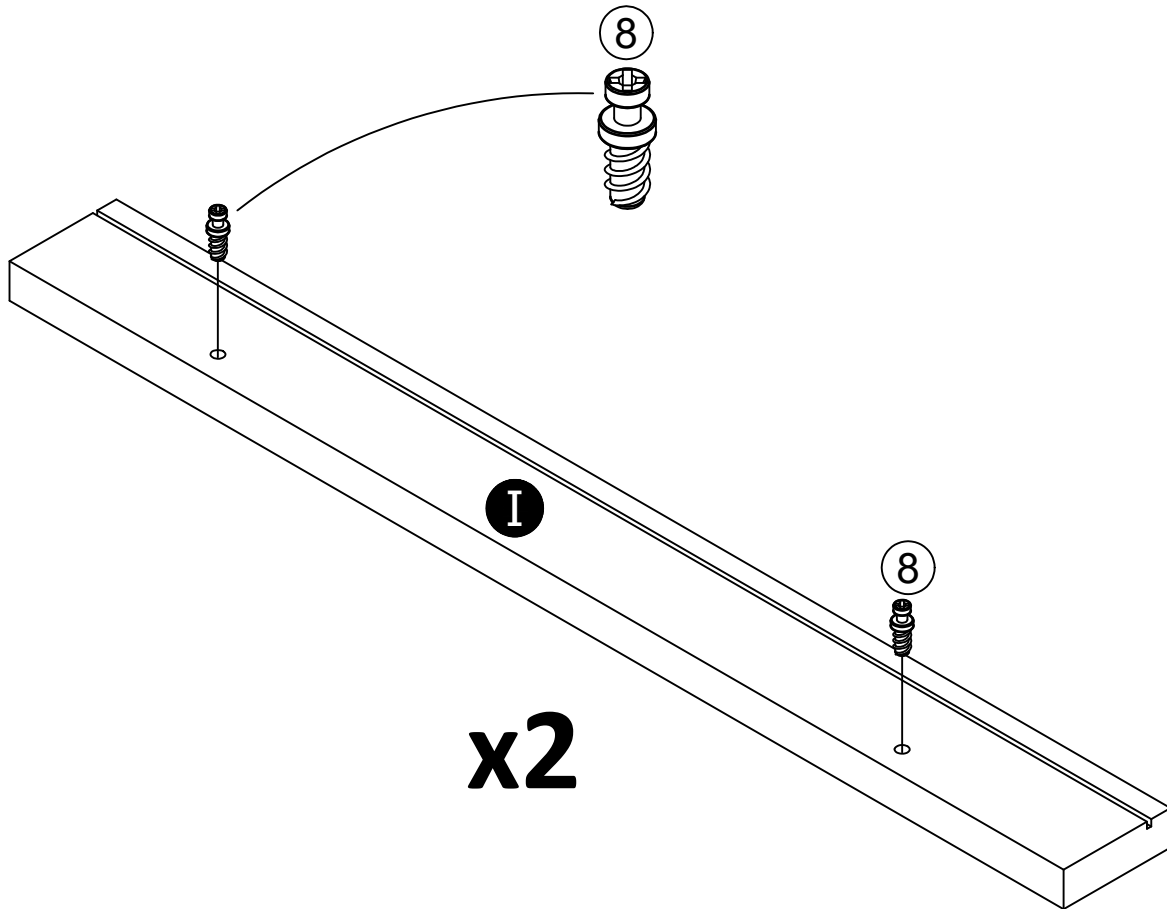

## STEP 4

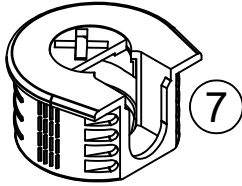
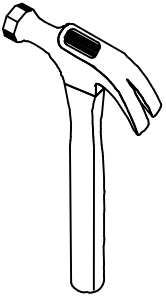

(x4)  
#A22920

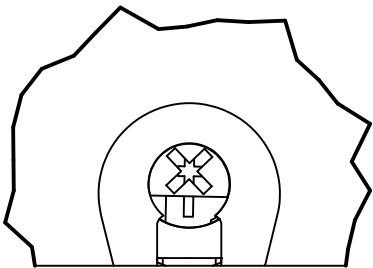
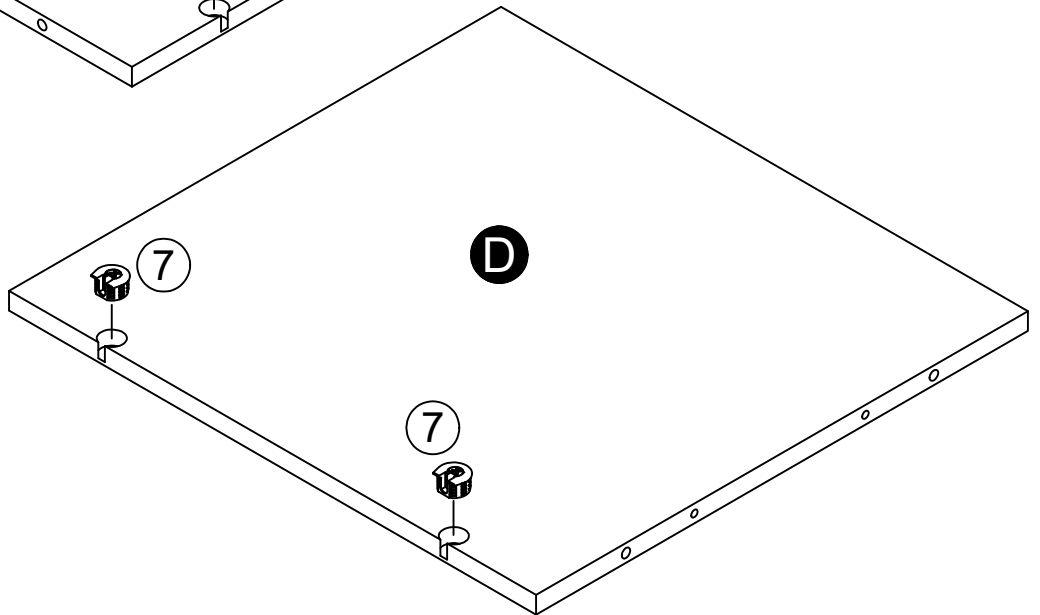
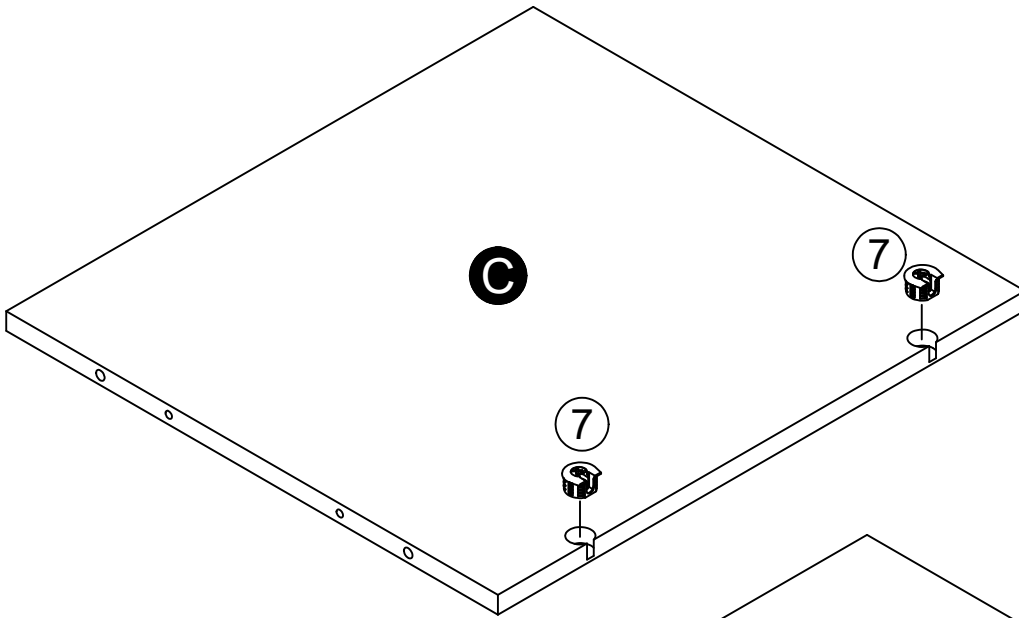

Note: Be sure the connector is positioned as shown before inserting into the hole.

# STEP 5

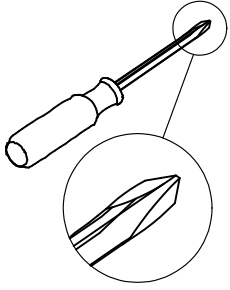

Important: Notice position of groove when attaching to panel.

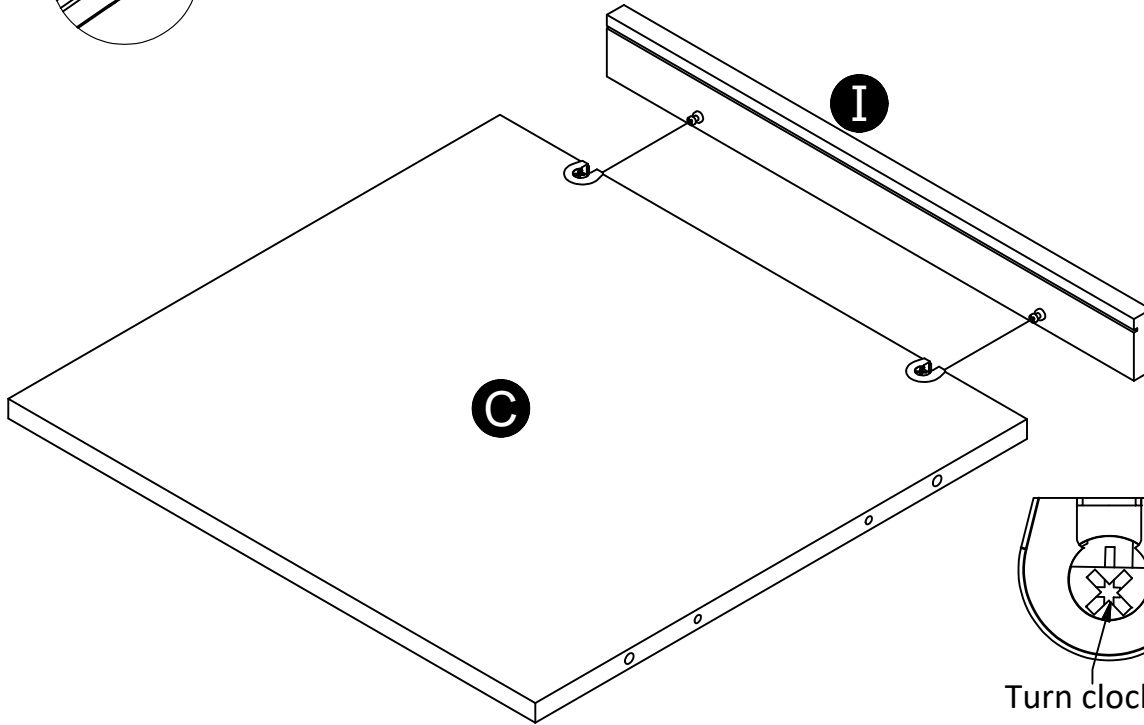

Important: Notice position of groove when attaching to panel.

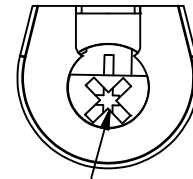

Turn clockwise to lock in place.

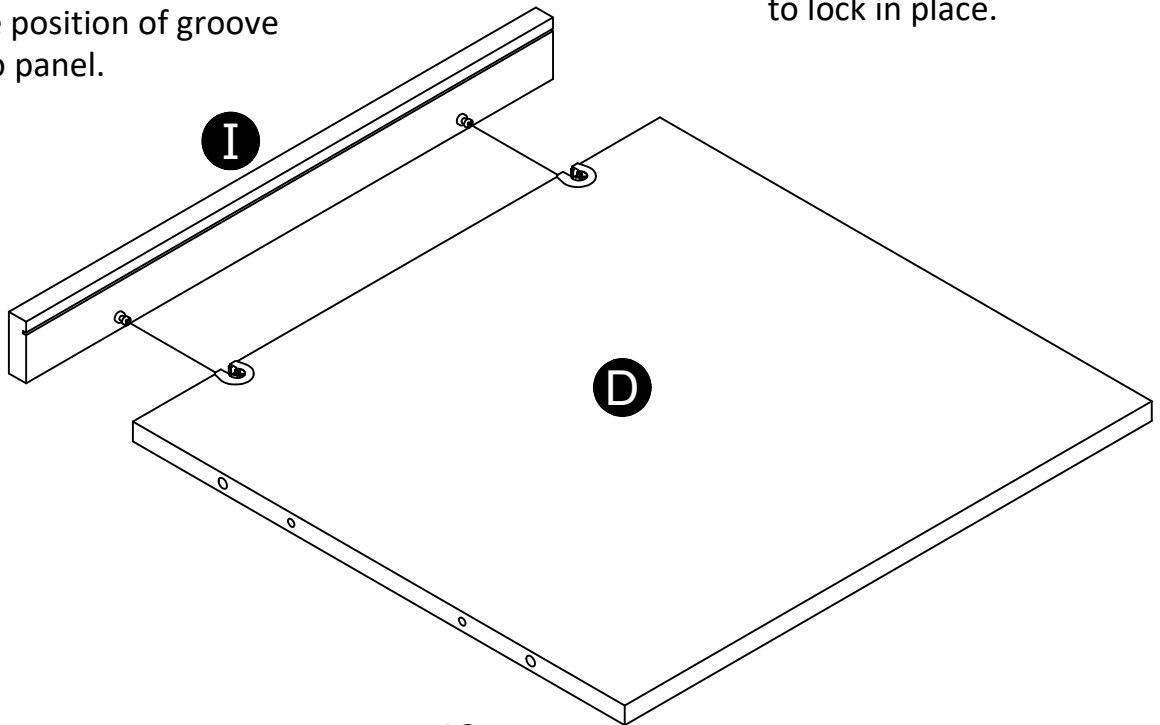

# STEP 6

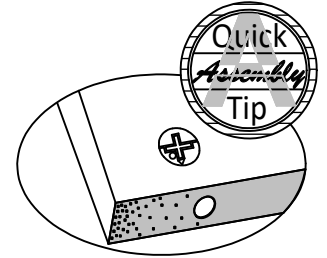
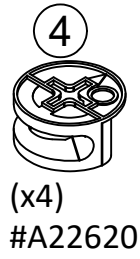
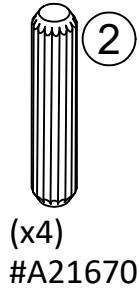

Proper orientation of CAM LOCK

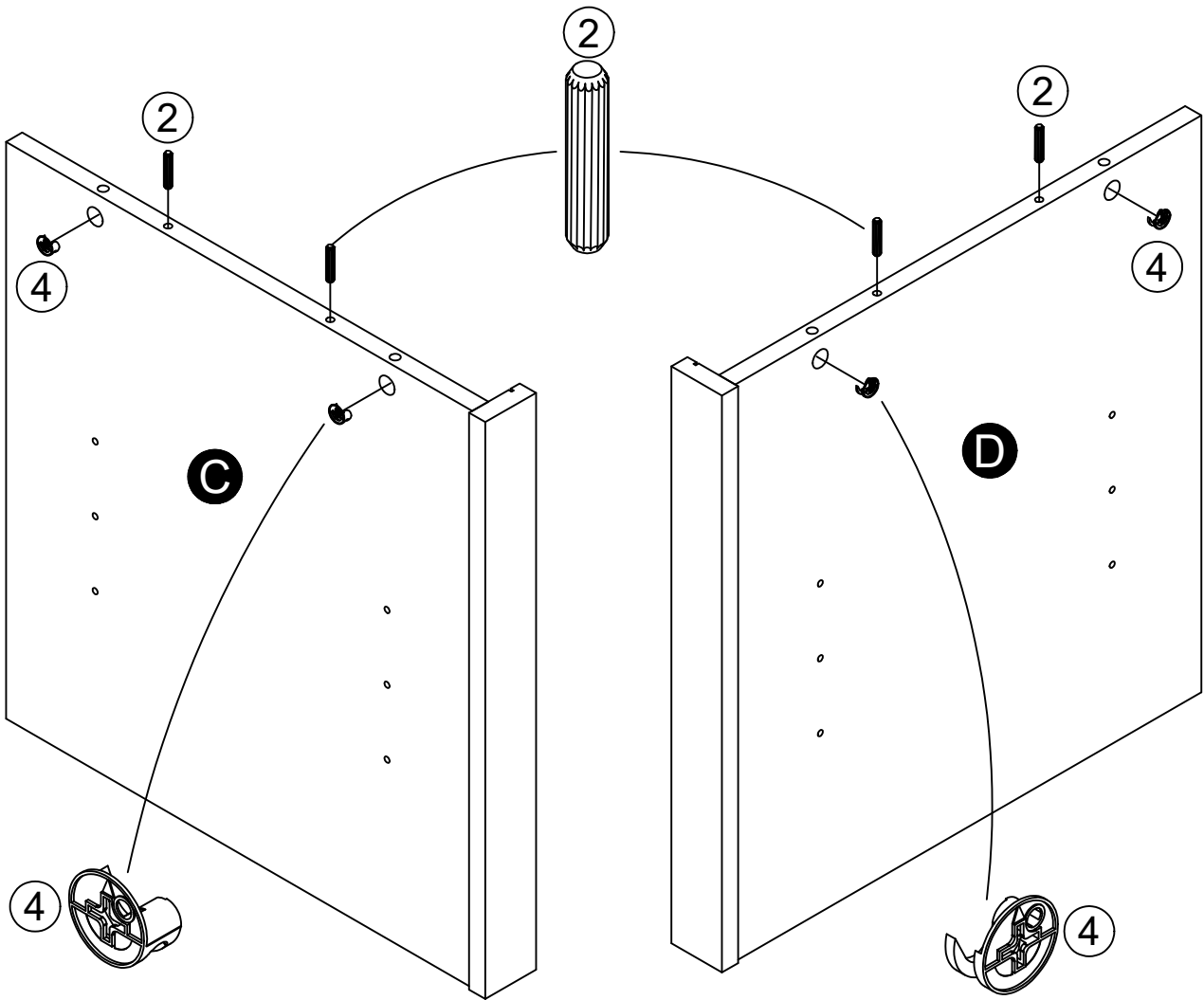

# STEP 7

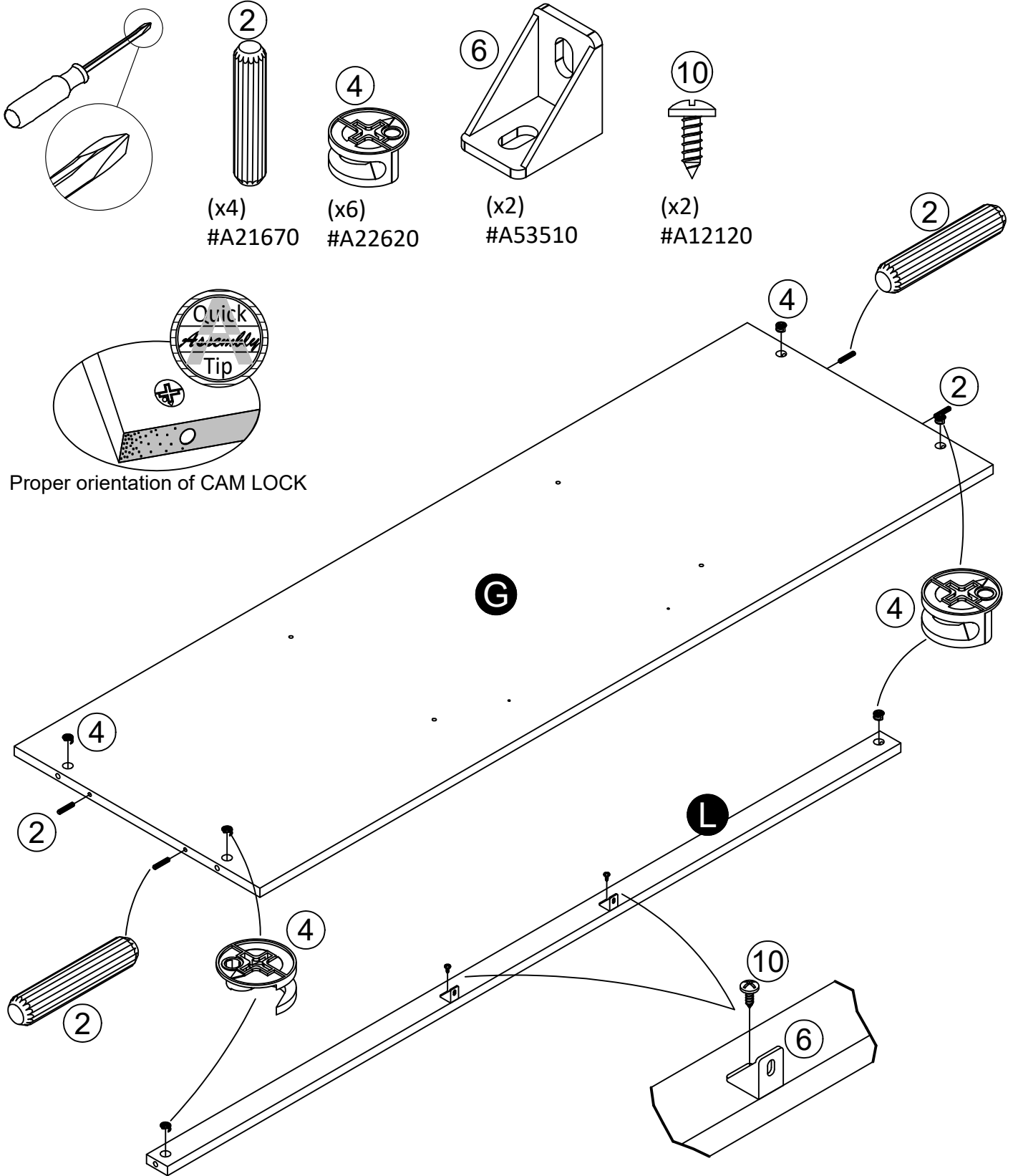

# STEP 8

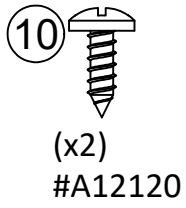
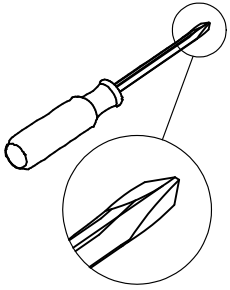

Note: DO NOT fully tighten this screw at this time.

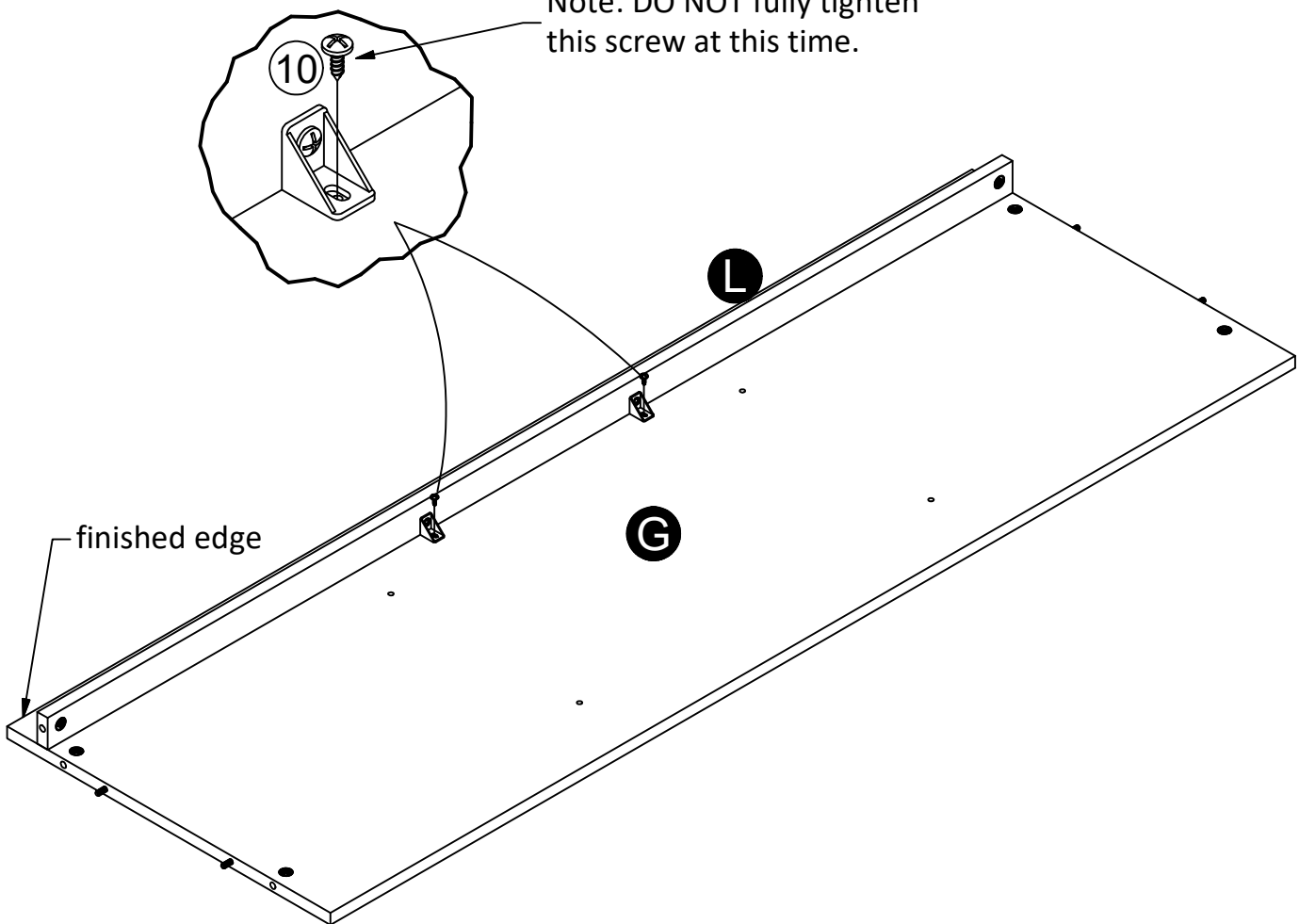

# STEP 9

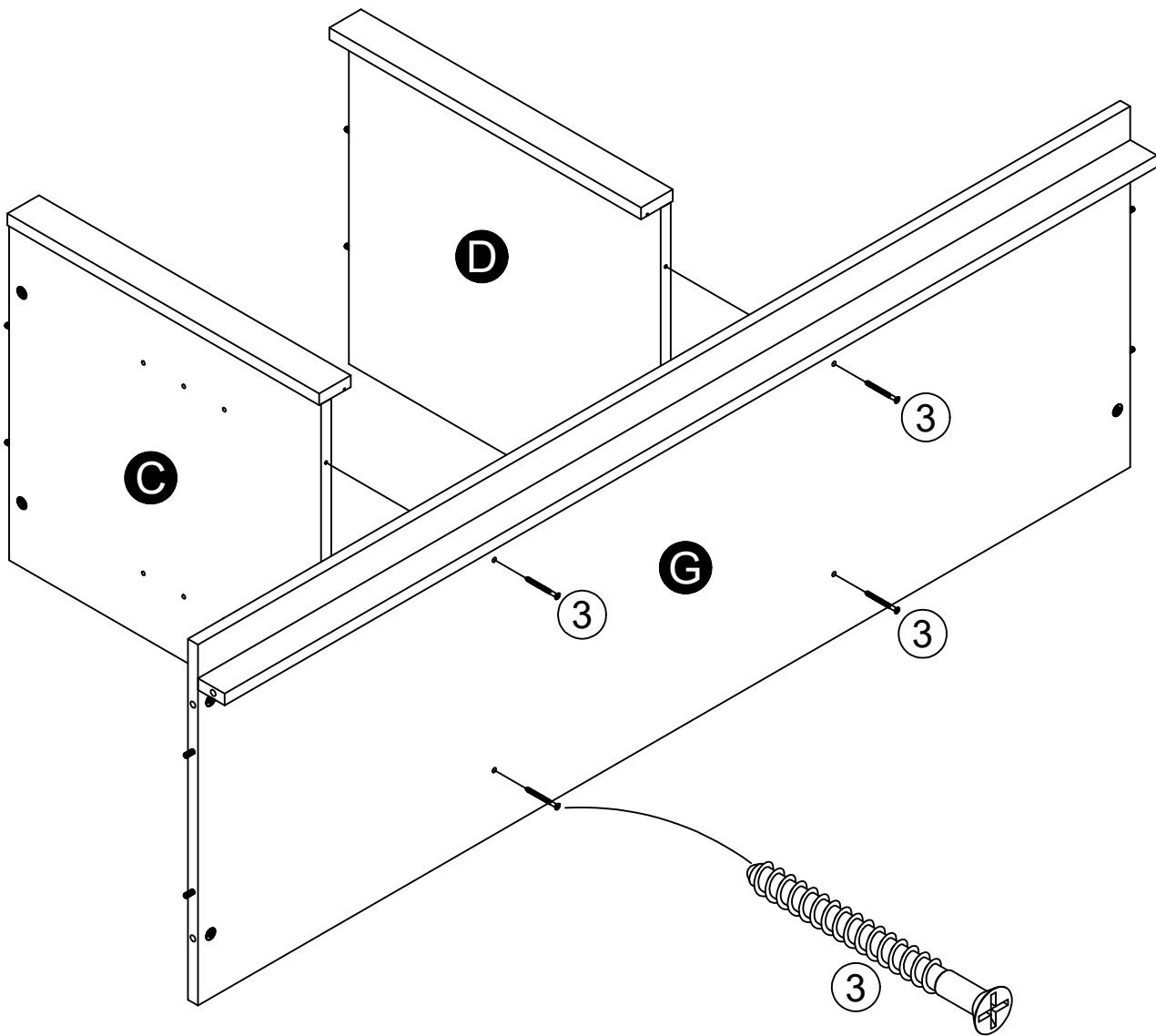
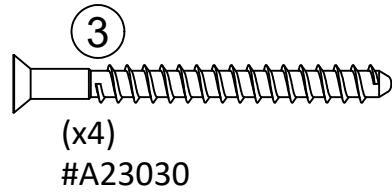
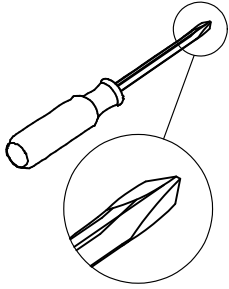



# STEP 10

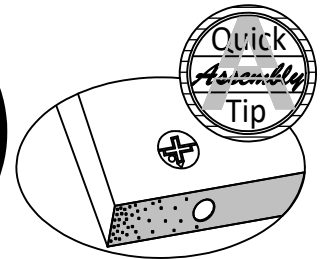
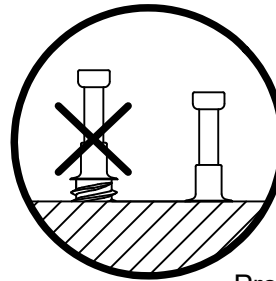
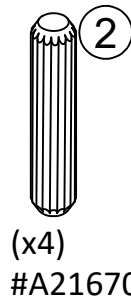
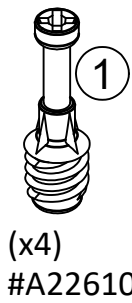
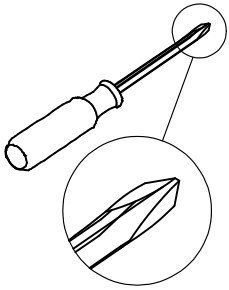

Proper orientation of CAM LOCK

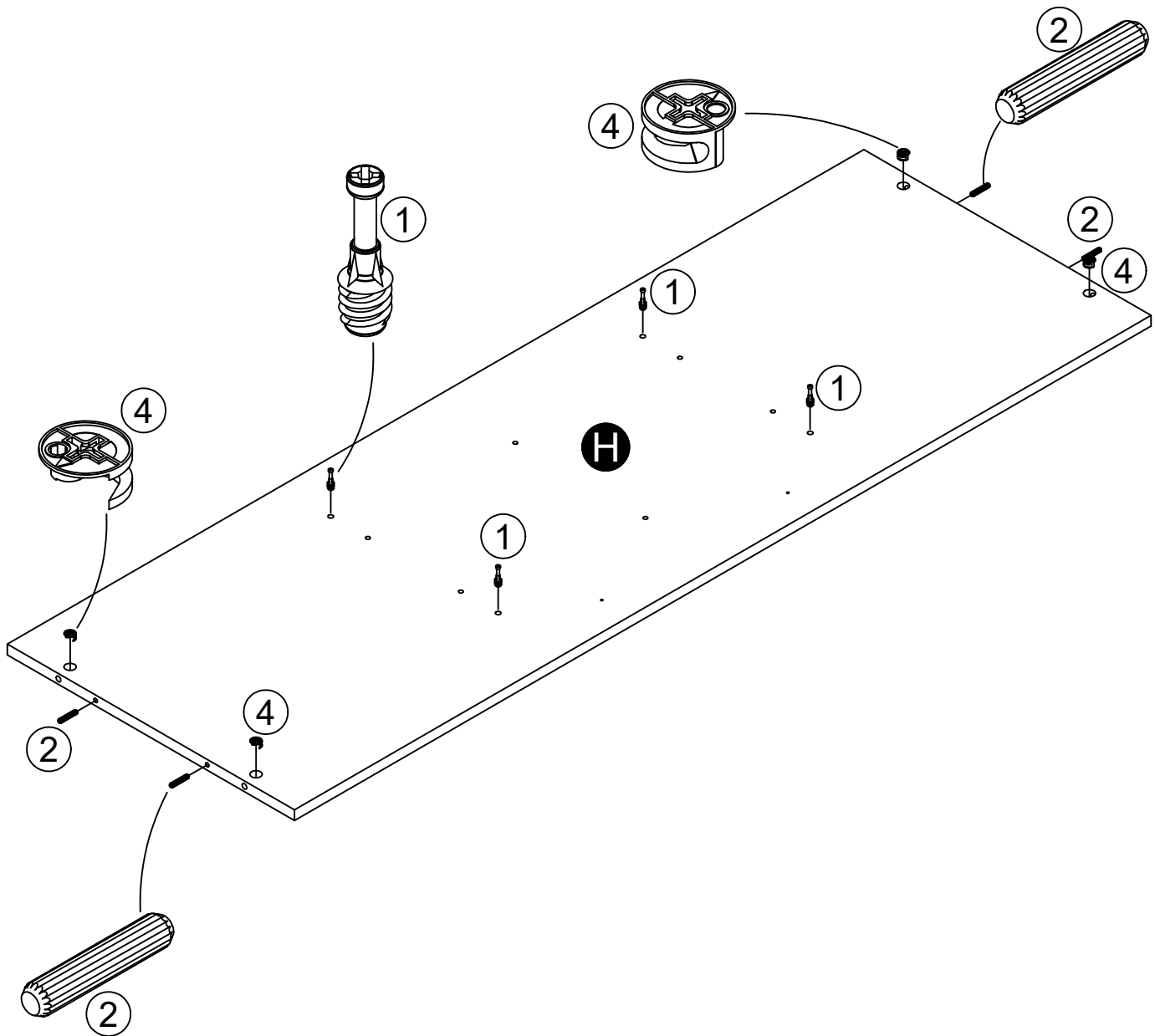

## STEP 11

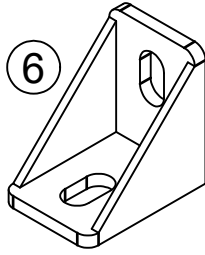
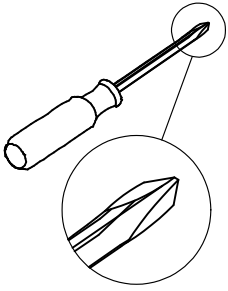

(x2)  
#A53510



(x4)  
#A12120

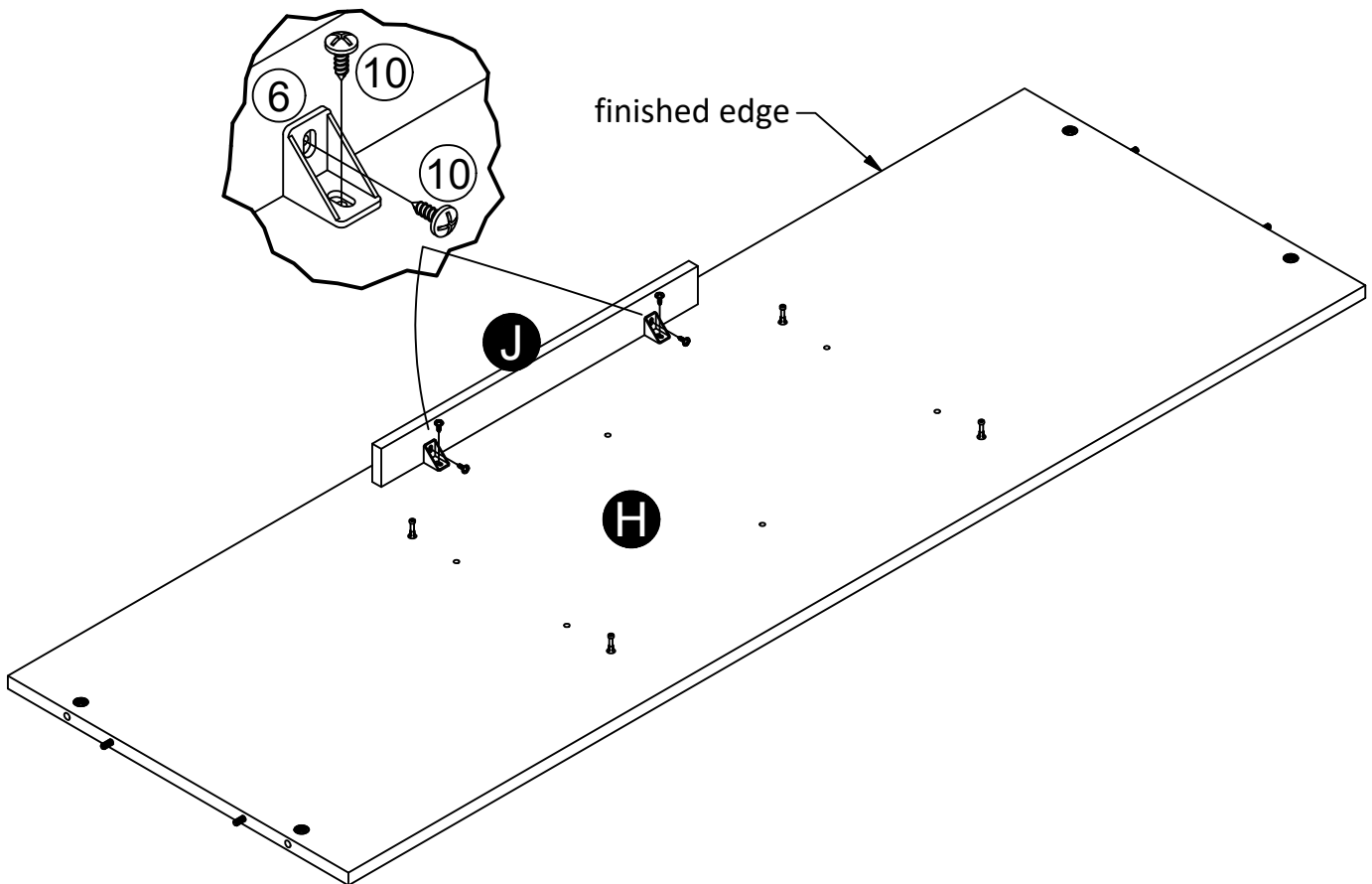

# STEP 12



(x1)  
#A21670



(x2)  
#A22620

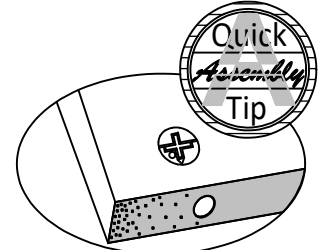

Proper orientation of CAM LOCK

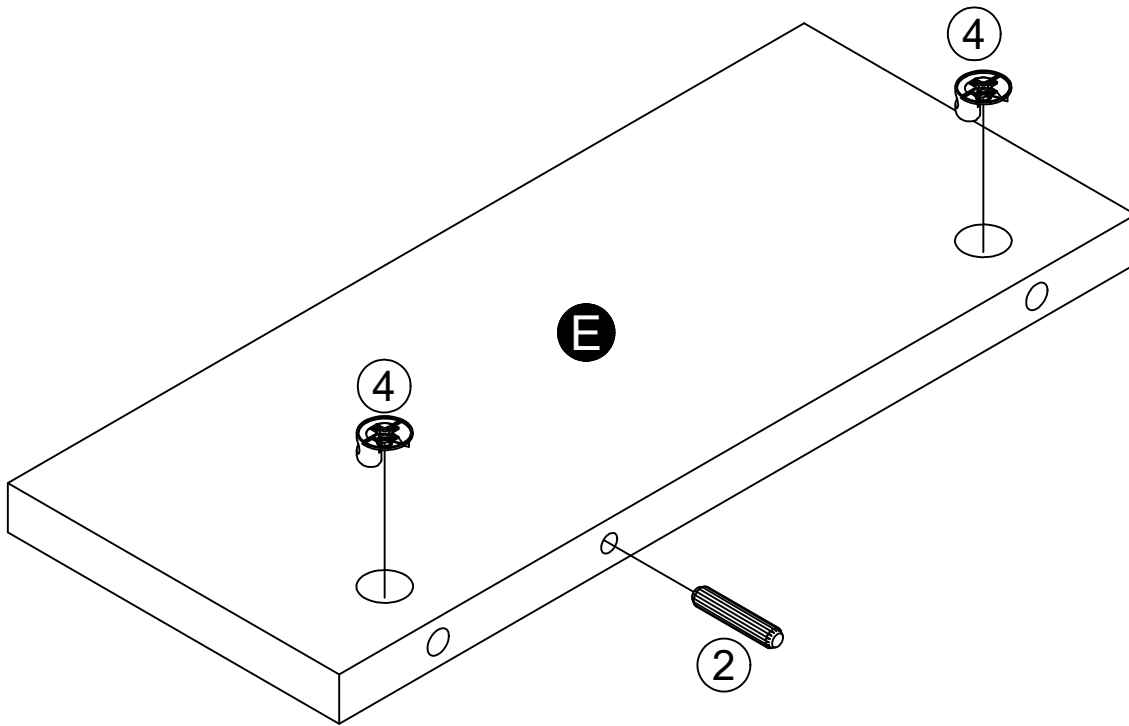

## STEP 13

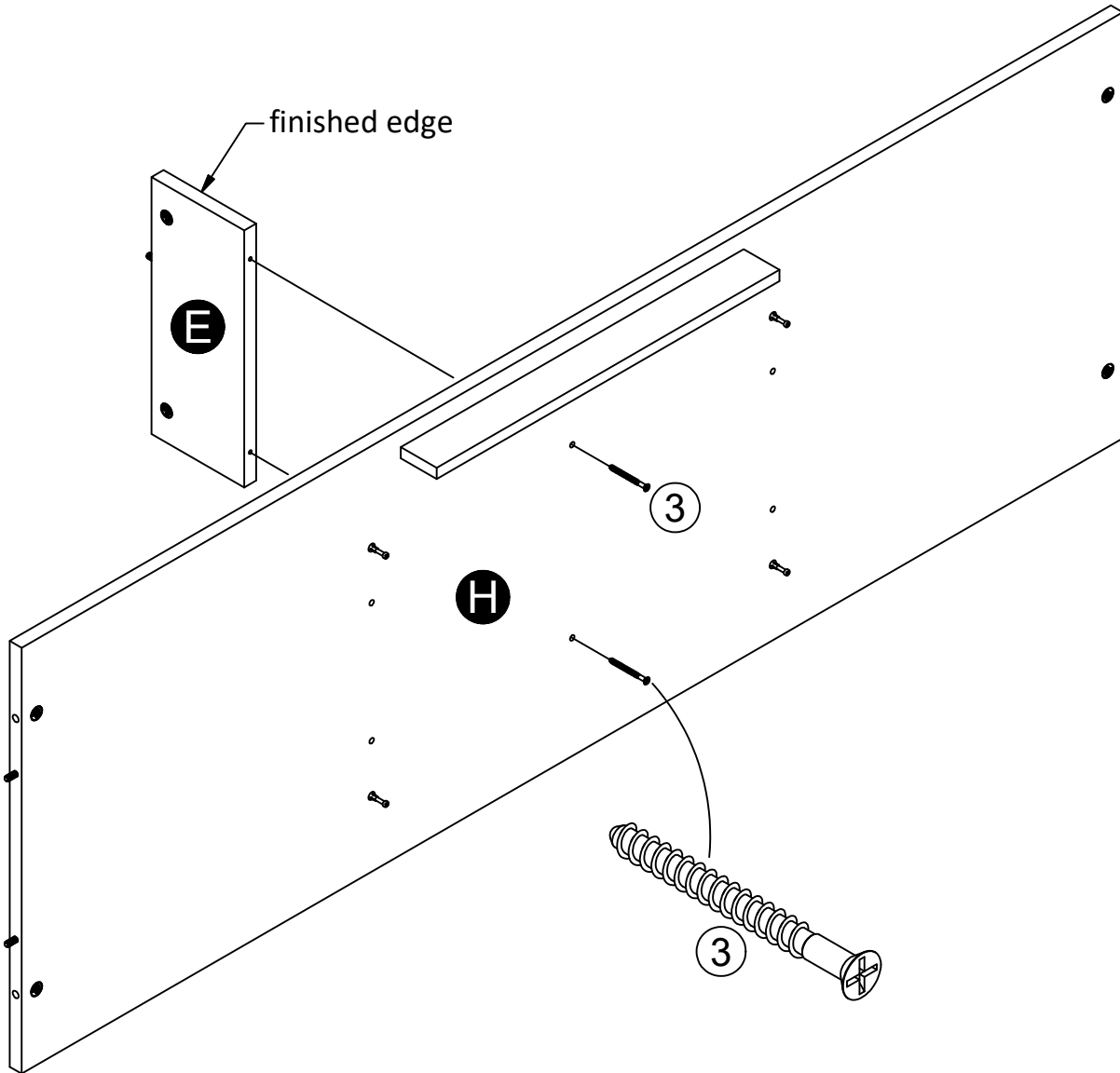
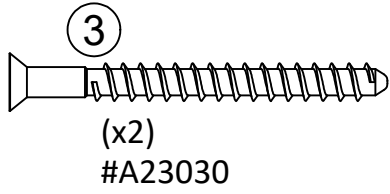
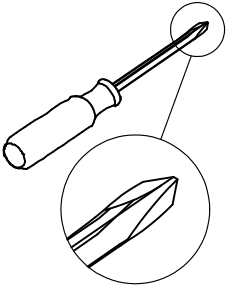

# STEP 14

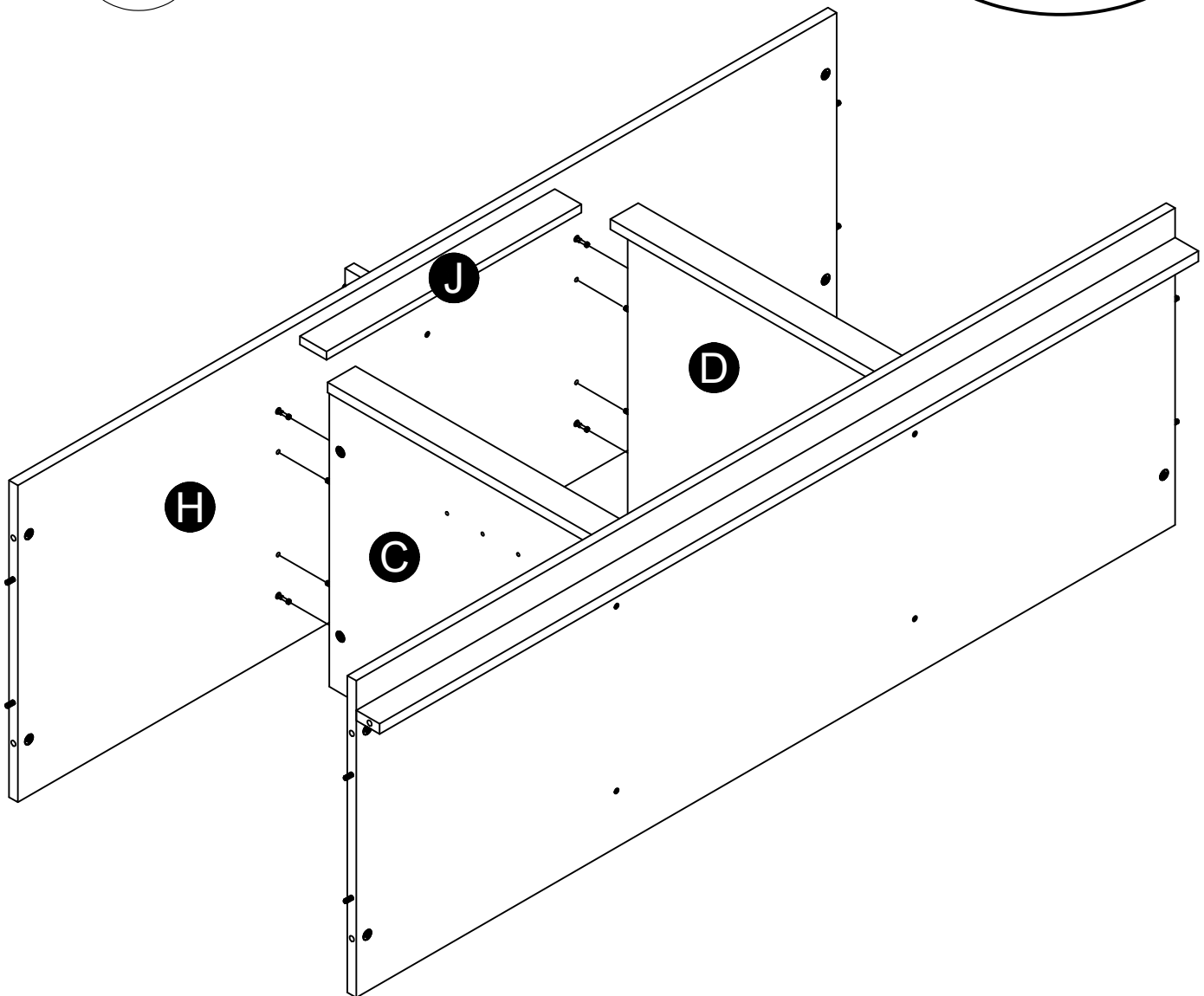
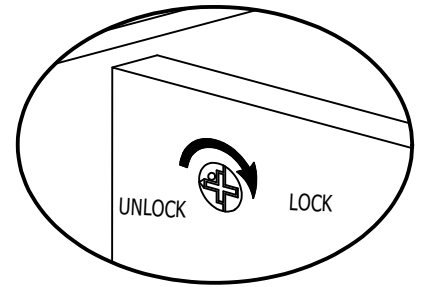
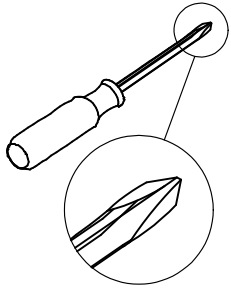

After shelf (H) is attached. Make sure the back surface of the horizontal rail (J) and back surface of the vertical rails (I) are flush with each other. If needed, loosen angle bracket screw (10) in the shelf (H) and adjust the horizontal rail (J).

# STEP 15

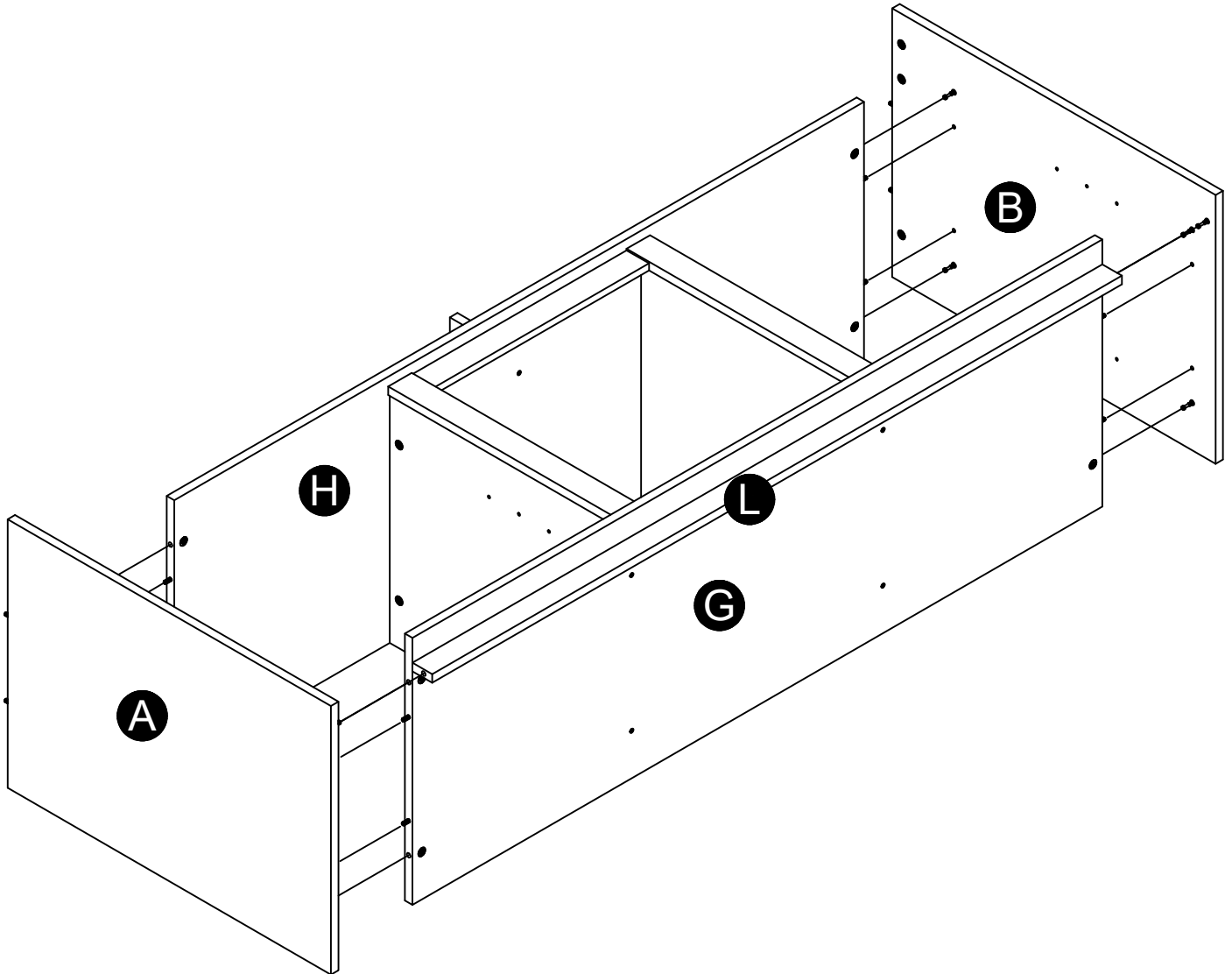
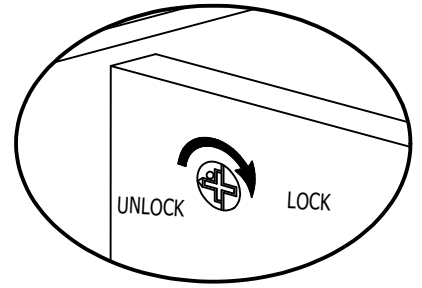
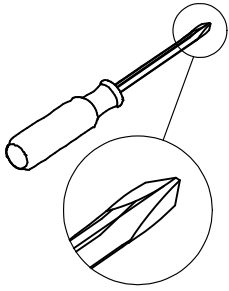

**Note: Fully tighten screws that were left loose in step 8.**

# STEP 16

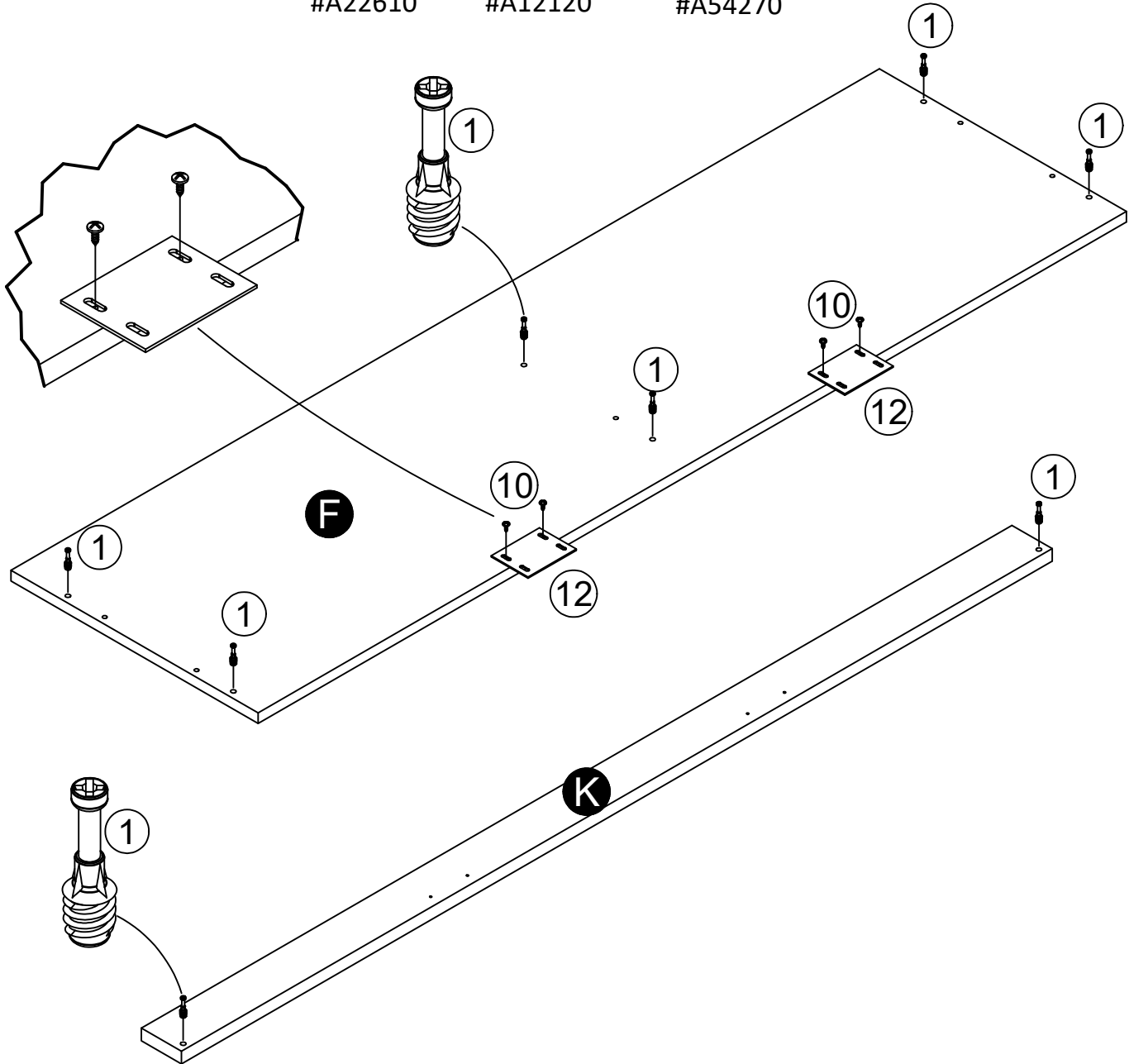
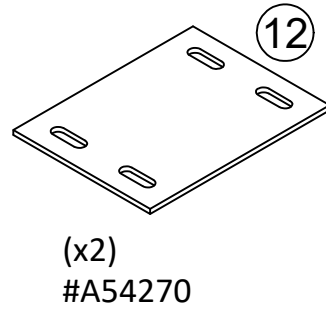
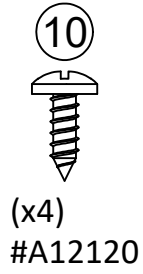
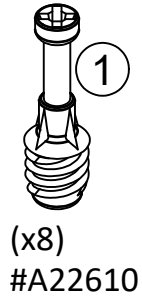
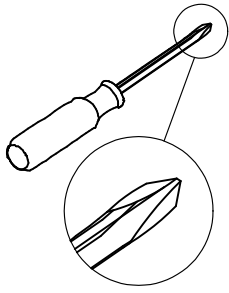

# STEP 17

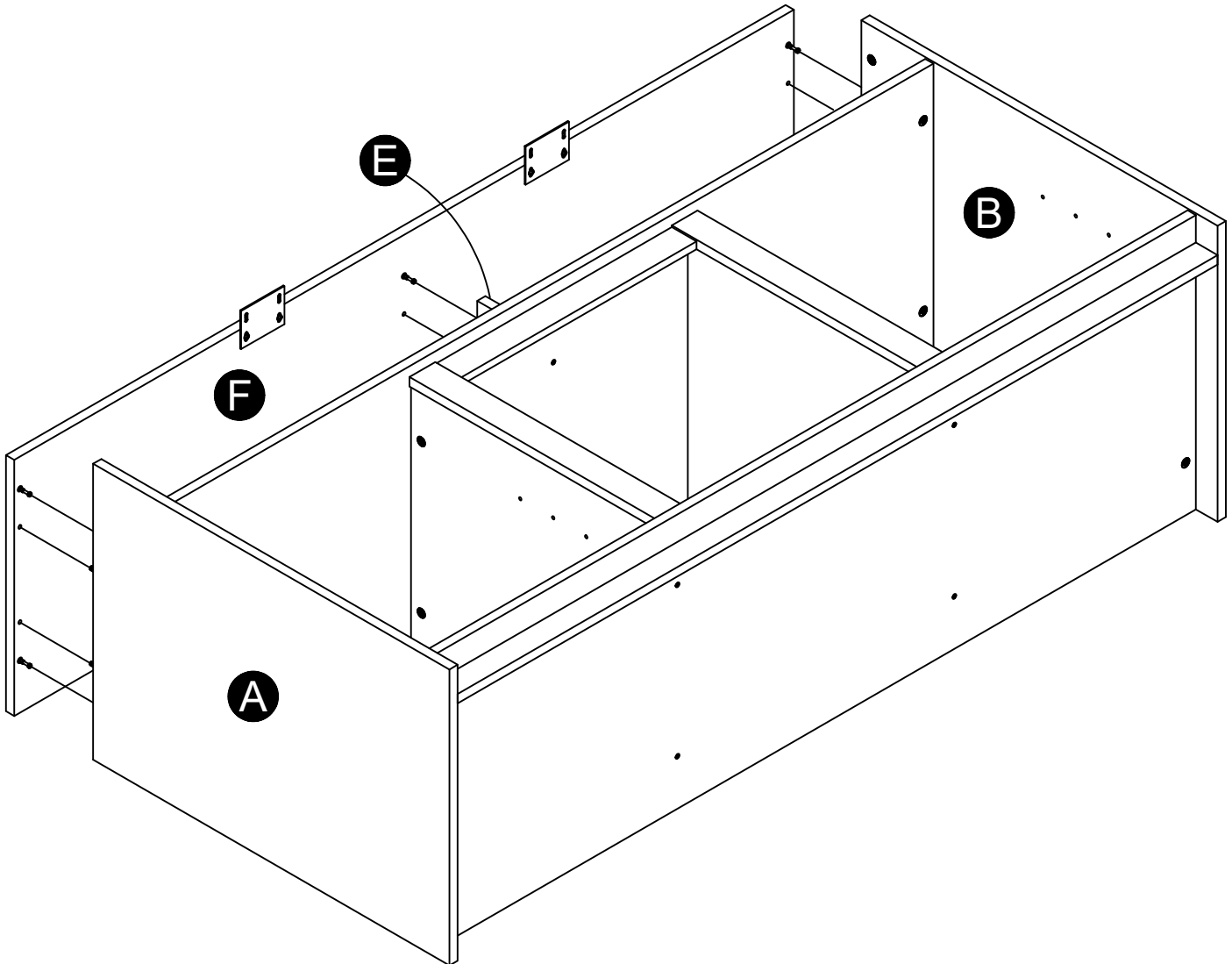
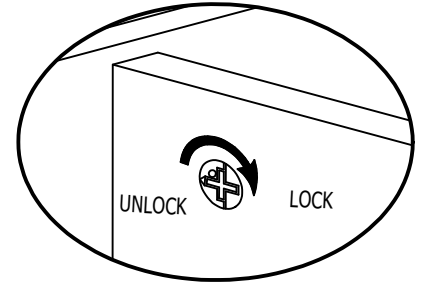
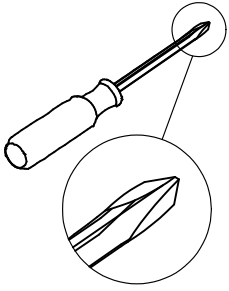



# STEP 18

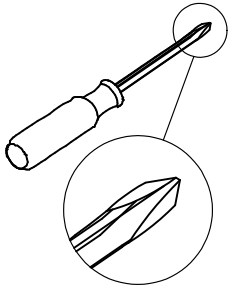

10  
(x4)  
#A12120

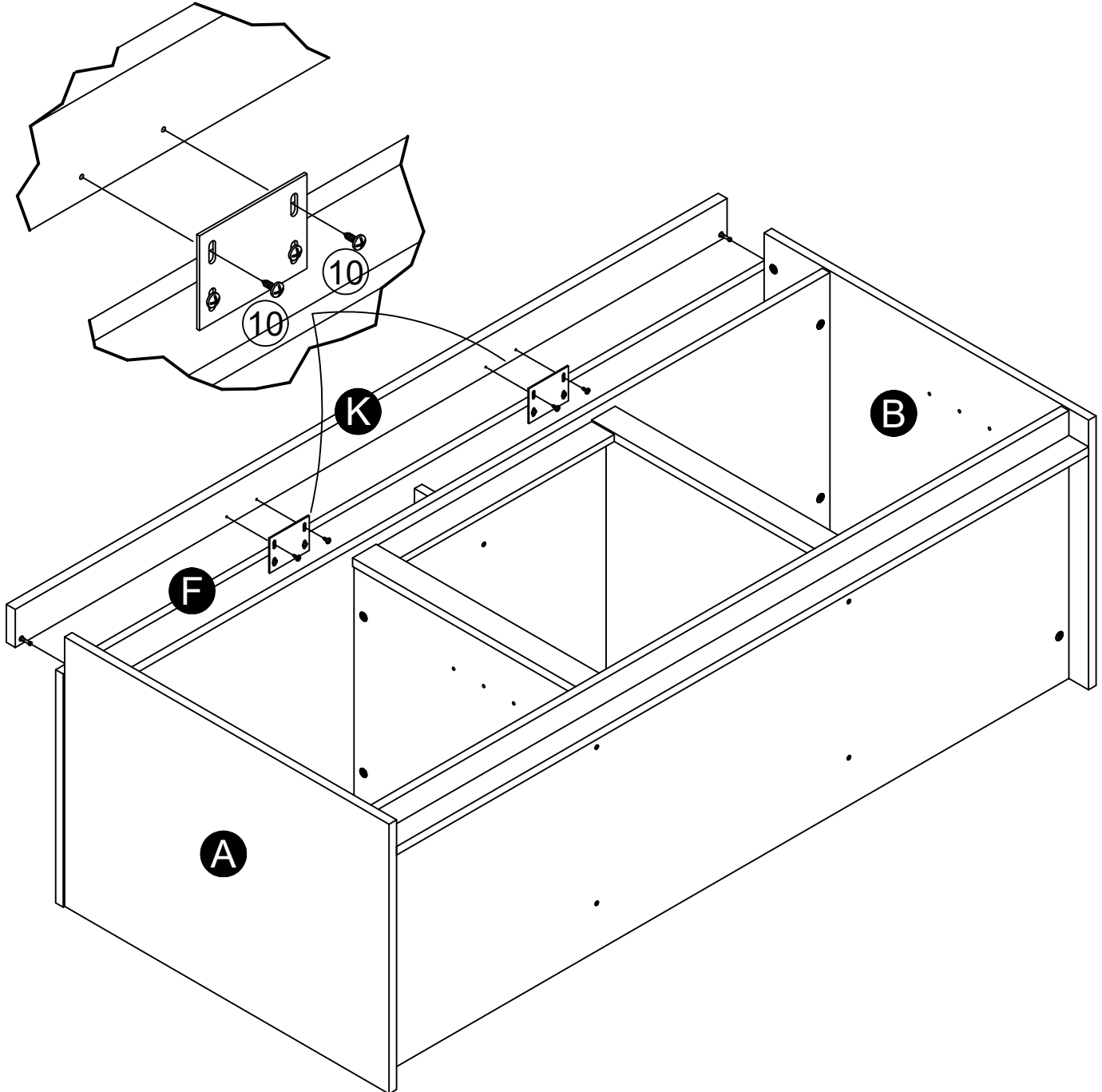
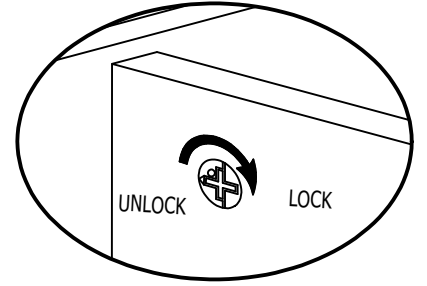

# STEP 19

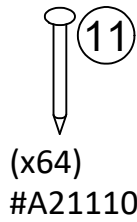
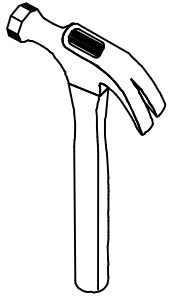

**IMPORTANT! THE BACK PANEL IS A STRUCTURAL PART OF THIS UNIT AND MUST BE INSTALLED PROPERLY.**

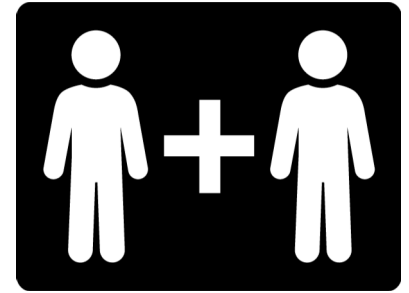

With the help of another person, carefully turn your unit over on its front side as shown. Position back panels as shown. Align squarely and nail (11) straight into back edges as shown.

Assure that your unit is square. Distance from corner to corner must be equal as shown

Attach after bottom two back panels are on.

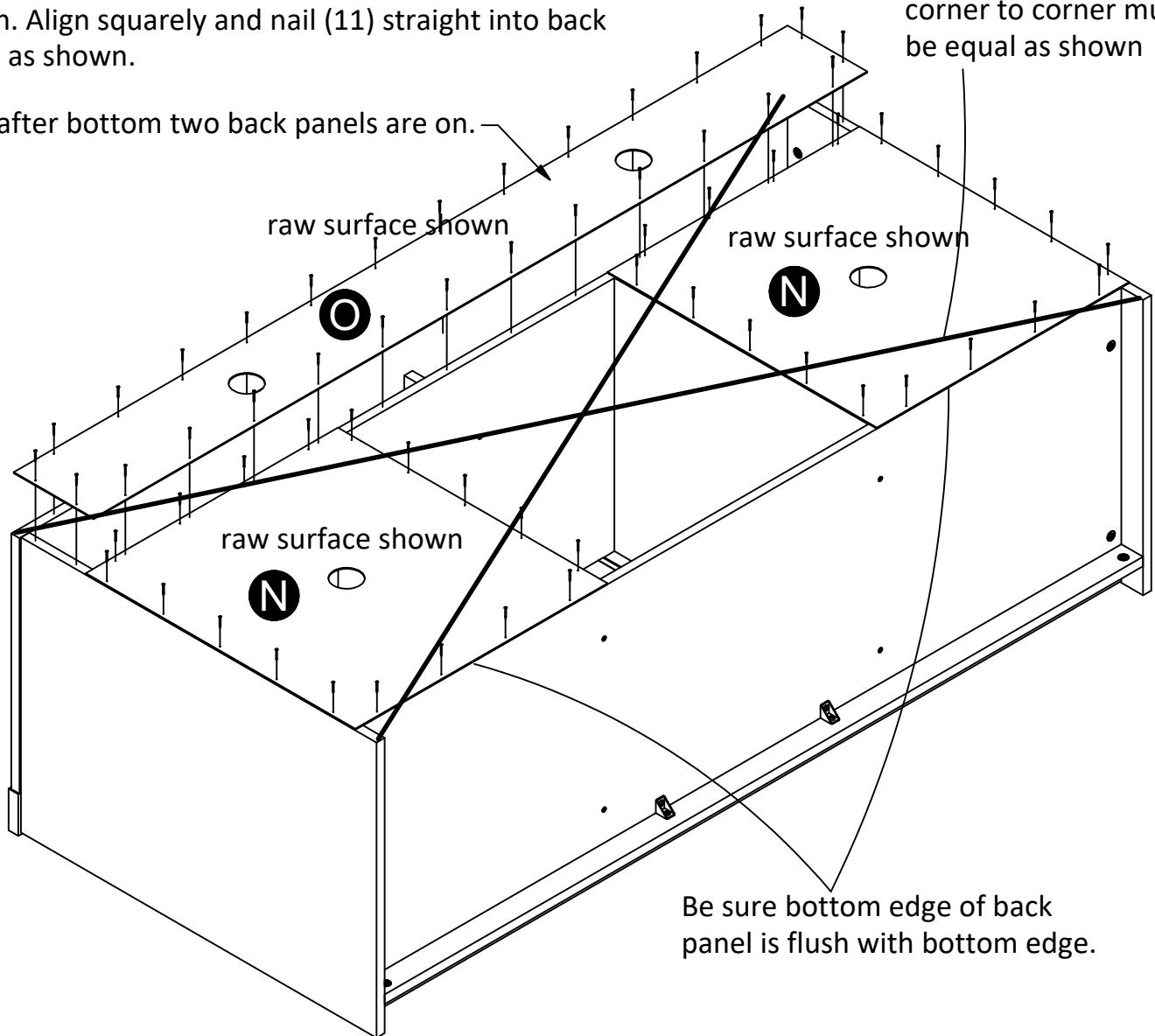

# STEP 20

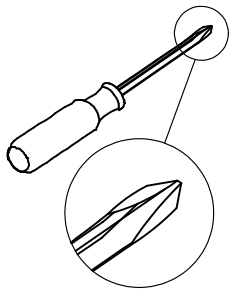

(10)  
(x6)  
#A12120

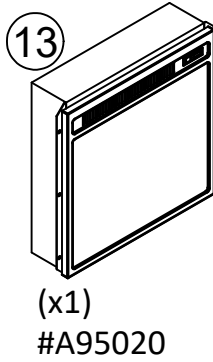

(13)  
(x1)  
#A95020

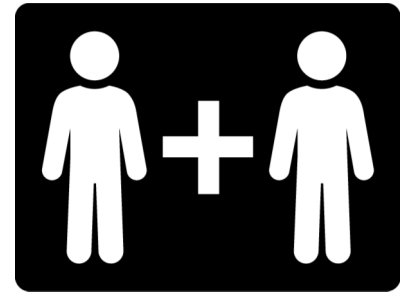

Carefully stand your unit upright. Using screws (10), mount the fireplace insert as shown.

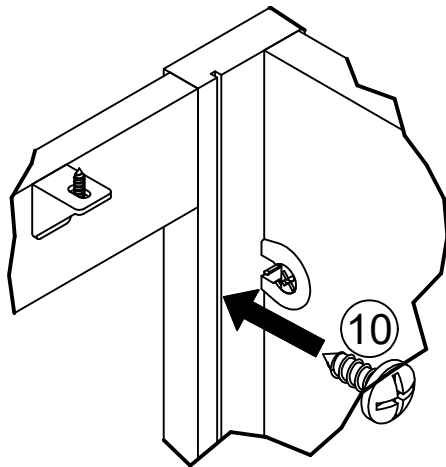

Note: When mounting fireplace insert, screws (10) will screw into groove in the vertical rails (1).

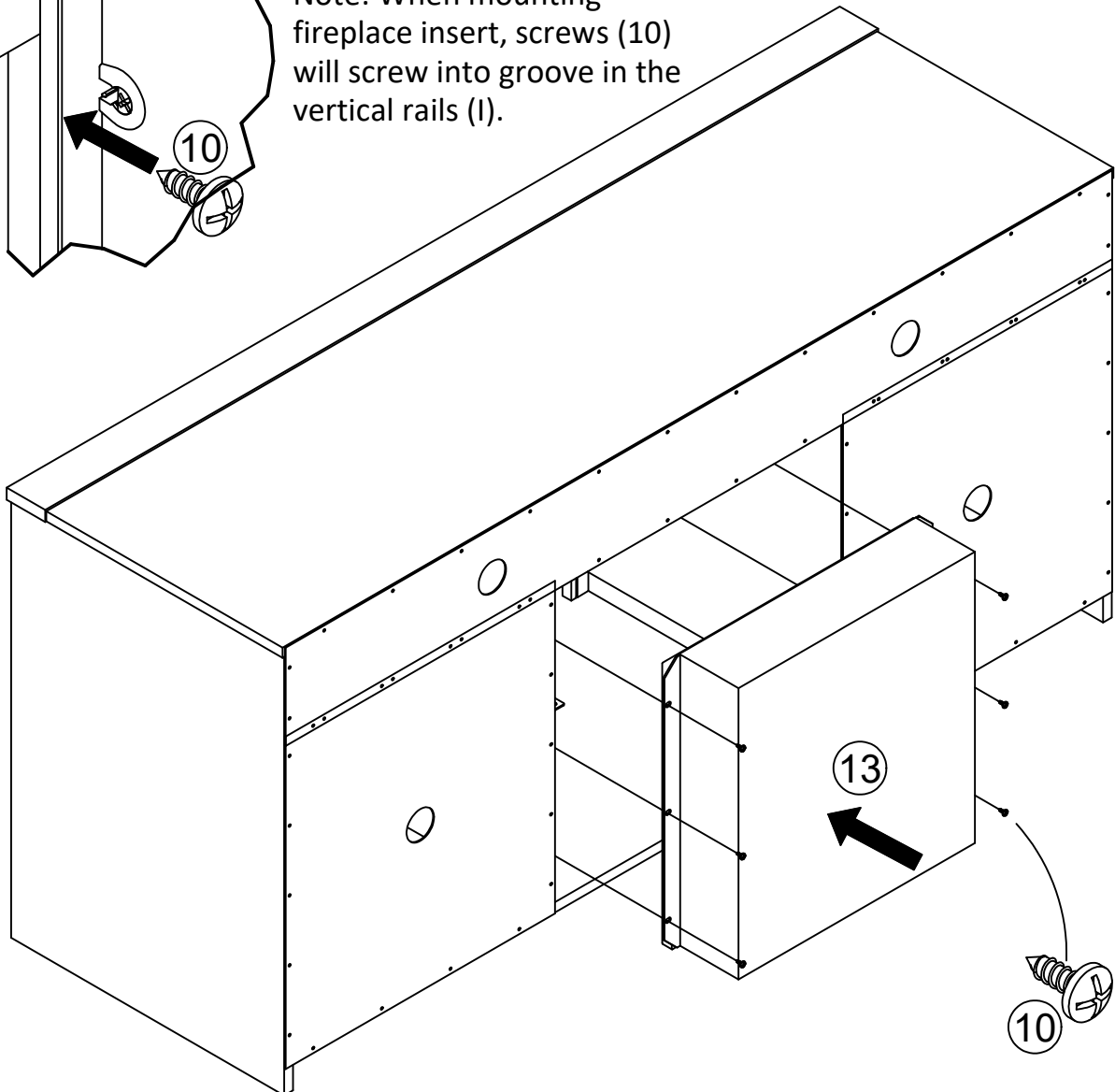

## STEP 21

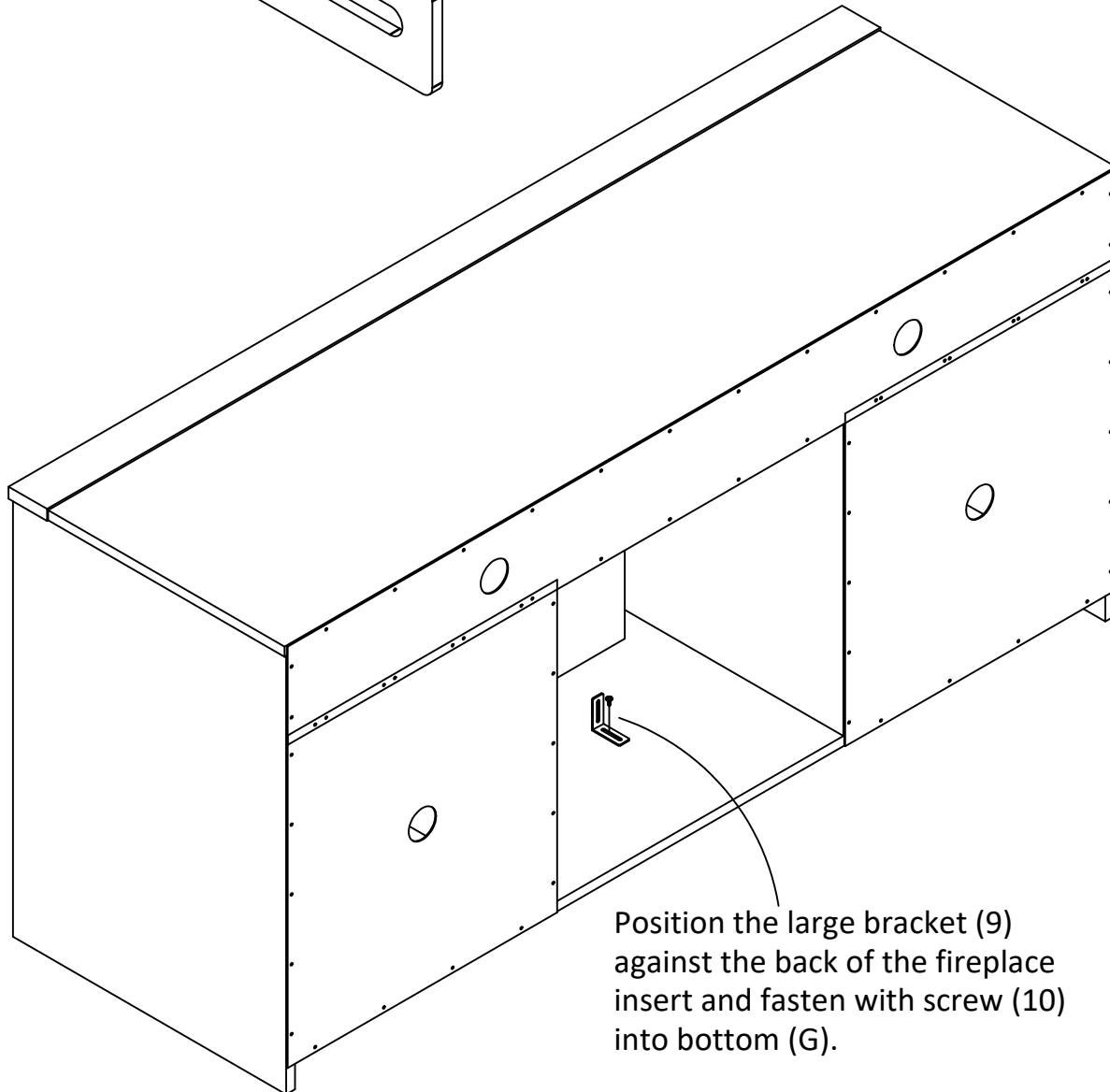
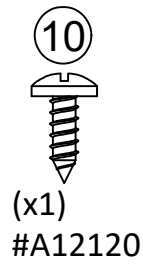
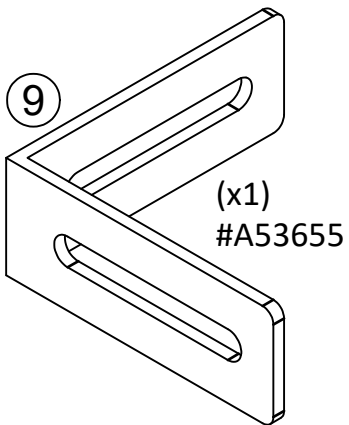
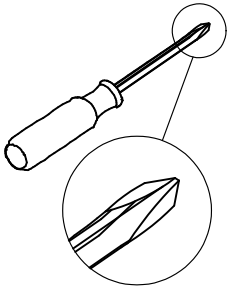

Position the large bracket (9) against the back of the fireplace insert and fasten with screw (10) into bottom (G).

# STEP 22

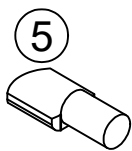

(x8)  
#A80250

Position your unit into your preferred location. Using shelf supports (5), install adjustable shelves (M).

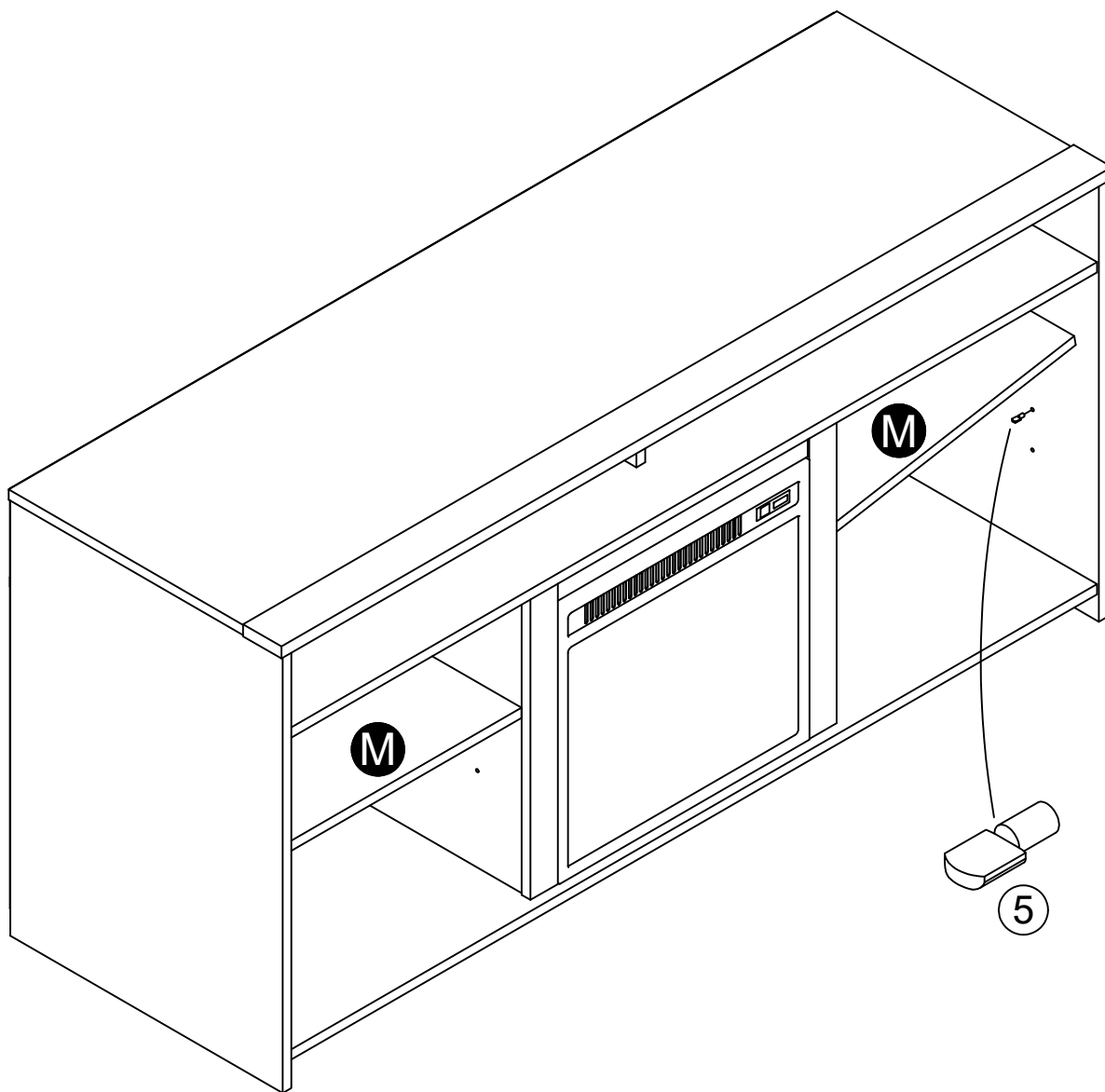

## Maximum Loads

This unit has been designed to support the maximum loads shown. Exceeding these load limits could cause sagging, instability, product collapse, and/or serious injury.

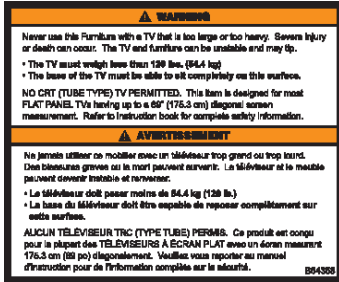

Apply the TV Warning Label to your unit for future reference. Please Note: Once TV Warning Label is applied, you will not be able to remove it.

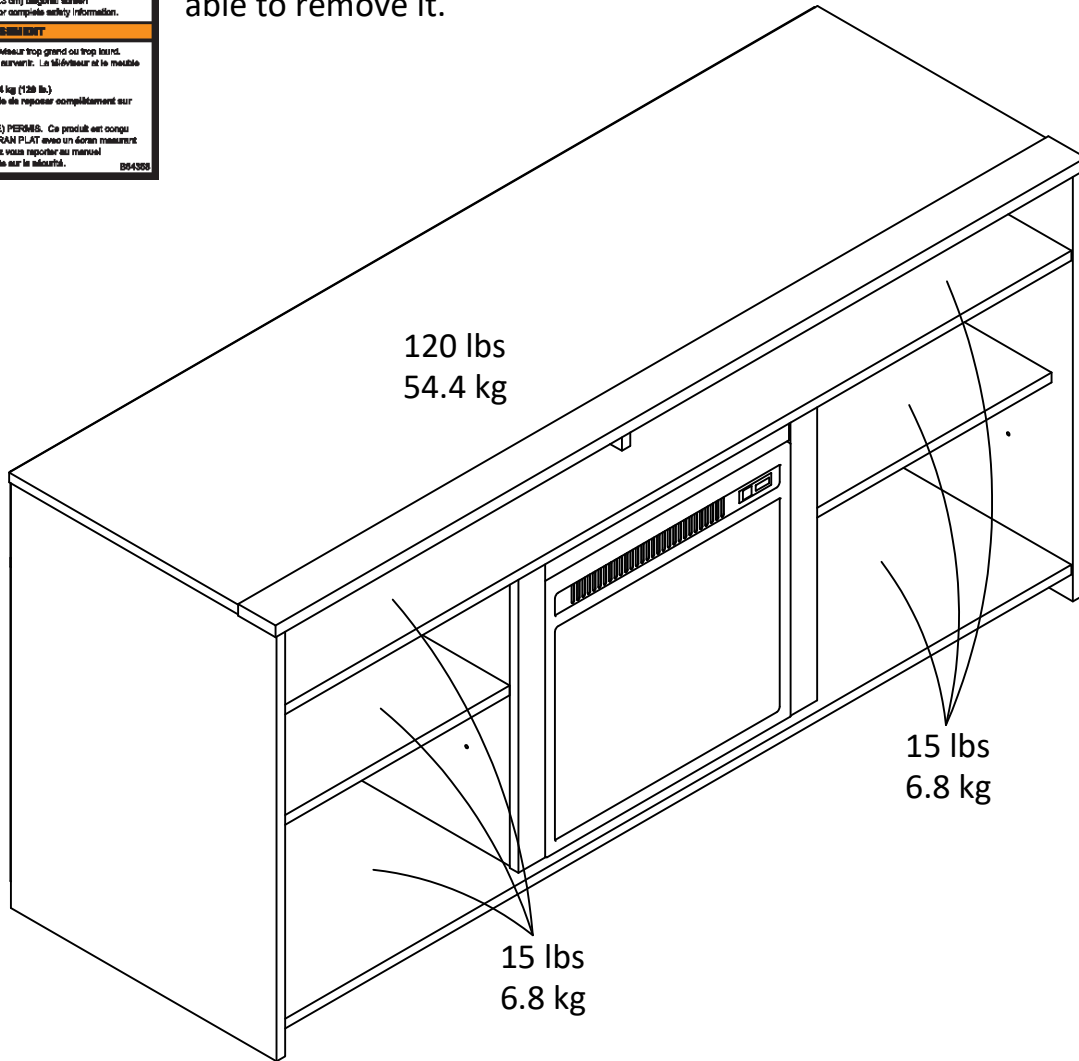

### Certificate of Conformity

1. This certificate applies to the Dorel Home Furnishings, Inc. product identified by this instruction manual.
2. This certificate applies to compliance of this product with the CPSC Ban on Lead-Containing Paint (16 CFR 1303).
3. This product is distributed by: Dorel Home Furnishings, Inc.

410 East First Street South  
 Wright City, MO 63390  
 636-745-3351

4. Site of Manufacture: Tiffin OH
5. See front page of instruction manual for date of manufacture.

---

## Register your product to receive the following:



- \* New trend details - sneak peek on what's new
- \* Surveys - have a voice within our community
- \* Exclusive deals and discount codes
- \* Quick and easy replacement part service

To register your product, visit [ameriwoodhome.com](http://ameriwoodhome.com)

## *5 Star Rating*



Visit your local retailer's website, rate your purchased product and leave us some feedback!

We would like to extend a big "Thank You" to all of our customers for taking the time to assemble this Ameriwood Home product, and to give us your valuable feedback.

*Thank  
You!*

## Cubierta Delantera

Este libro de instrucciones contiene información **IMPORTANTE** de seguridad. Por favor lea y manténgalo para referencia en el futuro.

**No Regrese este producto!** Comuníquese con nuestro amigoso equipo de servicio al cliente para obtener ayuda.

Llámenos al: 1-800-489-3351 (Gratis) Lunes - Viernes 9am - 5pm CST

**Visitar:** [www.ameriwoodhome.com](http://www.ameriwoodhome.com)

## PRECAUCION

Este mueble puede volcarse y causar graves heridas y/o muerte.

Anclar el mueble a un poste de madera en la pared (si esto se requiere).

No Permita que los niños monten el mueble.

Mantenga los artículos más pesados en los cajones de abajo.

## Consejos Útiles (página 2)

- Abra su artículo en el área donde usted planea utilizarlo para evitar levantar y moverlo menos
- Identificar, ordenar y contar las piezas antes de intentar ensamblar
- Las clavijas de compresión se golpean con un martillo
- Las diapositivas están marcadas con una R (derecha) y L (izquierda) para la colocación correcta
- Asegúrese de que siempre este el punto localizado en la parte superior de bloqueador de leva este volteado hacia borde exterior
- Utilizar todos los clavos para el panel de atrás y distribuirlos por igual
- El panel de atrás debe utilizarse para asegurarse de que la unidad quede fija y firme
- No use químicas fuertes ni limpiadores abrasivos en este artículo
- Nunca empuje, tire ni arrastre los muebles

## Antes de Que Empieces (página 3)

- Lea cuidadosamente cada paso y siga el orden correcto

- Separar y contar todas sus piezas y hardware

- Dése suficiente espacio para el proceso de ensamble

- Tenga las siguientes herramientas: destornillador de cabeza plana, #2 cabeza Phillips

Destornillador y martillo

- Precaución: Si usa un taladro electrónico o un destornillador eléctrico para atornillar, por favor asegúrese que deje de atornillar cuando el tornillo este apretado. Fallar hacer esto puede causar barrer el tornillo.

## Sistema de fijar el bloqueo de leva (página 3)

Esta sistema de fijar el bloqueo de leva sera usado en todo el proceso ensamble.

Página 4

Por favor tenga en cuenta: Podría necesitar golpear suavemente los tacos de madera para insertarlos en los agujeros durante el proceso de armado.



## Página 11

Nota: asegúrese de que el conector esté posicionado como se mostró arriba antes de insertarlo en el agujero.

## Página 12

Importante: Note la posición de la muesca cuando lo coloque en el panel  
Gire en sentido horario para ajustarlo.

## Página 15

Nota: por ahora NO ajuste totalmente este tornillo

## Página 21

Luego de que el estante (H) esté colocado asegúrese de que la superficie trasera de la guía horizontal (J) y la superficie posterior de los rieles verticales (I) estén alineados. Si fuera necesario afloje el tornillo del soporte angular (10) en el estante (H) y ajuste el riel horizontal (J)

## Página 22

Nota: ajuste totalmente los tornillos que se dejaron flojos en el paso 8.

## Página 26

**¡IMPORTANTE! EL PANEL TRASERO ES UNA PARTE ESTRUCTURAL DEL CONJUNTO Y DEBE SER COLOCADO CORRECTAMENTE.**

Asegúrese de que su mueble esté en escuadra. Las distancias de esquina a esquina deben ser las mismas, como se indica.

Asegúrese de que el borde inferior del panel trasero esté alineado con el borde inferior.

Con la ayuda de otra persona dé vuelta cuidadosamente la unidad sobre el lado frontal como se indica. Posicione los paneles posteriores como se muestra. Alinee en escuadra y clave (11) en los bordes posteriores como se indica.

Ajuste luego de que los dos paneles posteriores estén colocados.

## Página 27

Con cuidado pare verticalmente su unidad. Utilizando tornillos (10), monte el inserto para la chimenea como se muestra.

Nota: cuando monte el inserto para la chimenea, los tornillos (10) se ajustarán en las muescas de los rieles verticales (I)

## Página 28

Posicione el soporte grande (9) contra el dorso del inserto para la chimenea y ajuste con tornillos (10) en la parte de abajo (G).

## Página 29

Posicione su unidad en su lugar preferido. Utilizando los soportes para estante (5), instale los estantes ajustables (M).

## Página 30

### CARGA MAXIMA

Esta unidad ha sido diseñada para soportar la carga máxima anotada. El exceder estos límites puede causar inestabilidad, colapsarse y/o causar serias lesiones.

Aplique la etiqueta de advertencia de la TV en su unidad para referencia futura.

Por favor tenga en cuenta: una vez que la etiqueta de la TV se ha colocado, no podrá ser removida.

## Página 31

Registre su producto para recibir lo siguiente:

- \* Detalles de nuevas tendencias - Vistazo a lo nuevo
- \* Encuestas - alec su voz entre su comunidad
- \* Códigos de ofertas y descuentos exclusivos
- \* Fácil y rápido servicio de partes de remplace

Para registrar su producto, visite [ameriwoodhome.com](http://ameriwoodhome.com)

Clasificación de 5 estrellas

Visite el sitio web de su tienda local, califique su comprado y denos sus comentarios!

Nos gustaría enviar un gran "Agradecimiento" a todos nuestros clientes por tomarse el tiempo de ensamblar este producto de Ameriwood Home, y por darnos sus valiosos comentarios.

Gracias

## Couverture Avant

CE LIVRET D'INSTRUCTION CONTIENT DES INFORMATIONS **IMPORTANTES** SUR LA SÉCURITÉ. VEUILLEZ LIRE ET GARDER POUR UNE RÉFÉRENCE FUTURE

**Ne retournez pas ce produit!** Contactez notre équipe de service à la clientèle amicale d'abord pour obtenir de l'aide.

**Appelez-nous:** 1-800-489-3351 (sans frais) du Lundi au Vendredi de 9h à 17h Heure Centrale

**Visitez:** [www.ameriwoodhome.com](http://www.ameriwoodhome.com)

## ATTENTION

Le meuble peut basculer et causer des blessures graves ou la mort.

Ancrez le meuble à une planche murale dans le mur (si indiqué).

Ne laissez pas les enfants grimper sur le meuble.

Placez les articles lourds sur les étagères ou dans les tiroirs inférieurs.

## Astuces Utiles (page 2)

-Ouvrez votre article dans la zone que vous prévoyez de le garder pour moins de levage lourd

-Identifier, trier et compter les pièces avant d'essayer d'assembler

-Les goujons de compression sont taraudés avec un Marteau

-Les glissières sont marquées d'un R (droit) et d'un L (gauche) pour un bon placement

-Assurez-vous toujours de faire face la pointe situé sur le haut de la Serrure de Came vers le bord extérieur

-Utiliser tous les clous fournis pour le panneau arrière et les répartir également

-Le panneau arrière doit être utilisé pour vous assurer que votre appareil est robuste

-N'utilisez pas de produits chimiques agressifs ou de nettoyeurs abrasifs sur cet appareil

-Ne jamais pousser, tirer, ou faire glisser votre meuble

## Avant de Commencer (page 3)

-Lisez attentivement chaque étape et suivez le bon ordre

-Séparez et comptez toutes vos pièces et matériaux

-Donnez-vous suffisamment de place pour l'assemblage

-Avoir les outils suivants: tournevis à tête plate, #2 tournevis Phillips, et Marteau

-Attention: Si vous utilisez une perceuse électrique ou un tournevis électrique pour visser, veillez à ralentir et arrêter lorsque la vis est bien serrée. Le non-respect de cette consigne peut endommager la vis.

## Système de Fixation de Came (page 3)

Ce Système de Fixation de Came sera utilisé tout au long de l'assemblage

## Page 4

Veillez prendre note : Vous devrez peut-être taper légèrement sur les goujons en bois à insérer dans les trous lors de l'assemblage.

## Page 11

Remarque : Assurez-vous que le connecteur est positionné comme indiqué avant de l'insérer dans le trou.

## Page 12

Important : notez la position de la rainure quand vous la fixerez au panneau. Tournez dans le sens des aiguilles d'une montre pour verrouiller en position.

## Page 15

Important : NE serrez PAS complètement cette vis pour le moment.

## Page 21

Après avoir fixé l'étagère (H). Assurez-vous que la surface arrière de la traverse horizontale (J) et la surface arrière des traverses verticales (I) sont alignées l'une par rapport à l'autre. Si nécessaire, desserrez la vis de support d'angle (10) dans l'étagère (H) et ajustez la traverse horizontale (J).

## Page 22

Remarque : serrez à fond les vis qui n'avaient pas été totalement serrées à l'étape 8.

## Page 26

**IMPORTANT! LE PANNEAU ARRIÈRE EST UNE PARTIE ESSENTIELLE DE CET ENSEMBLE ET DOIT ÊTRE INSTALLÉ CORRECTEMENT.**

Assurez-vous que votre unité est bien à l'équerre. La distance d'un coin à l'autre doit être égale comme indiqué

Assurez-vous que le bord inférieur du panneau arrière est au même niveau que le bord inférieur.

Avec l'aide d'une autre personne, retournez soigneusement votre unité sur sa face avant, comme indiqué. Positionnez les panneaux arrière comme indiqué. Alignez-les à l'équerre et fixez-les (11) directement aux bords arrière comme indiqué.

Fixez les deux panneaux arrière une fois qu'ils sont en place.

## Page 27

Mettez délicatement votre unité en position verticale. À l'aide de vis (10), montez le foyer encastrable comme indiqué.

Remarque : Lors du montage du foyer encastrable, les vis (10) se fixent dans la rainure des traverses verticales (I).

## Page 28

Placez le grand support (9) contre l'arrière du foyer encastrable et fixez-le avec la vis (10) au fond (G).

## Page 29

Positionnez votre unité à l'endroit de votre choix. À l'aide de supports d'étagères (5), installez des étagères réglables (M).

## Page 30

### CHARGES MAXIMALES

Ce meuble a été conçu pour supporter les charges maximales indiquées. En excédant ces limites de charge, le meuble pourrait devenir instable, s'effondrer, et/ou causer des blessures graves.

Appliquez l'étiquette d'avertissement pour télé sur votre unité pour servir de référence ultérieurement.

Remarque : une fois l'étiquette d'avertissement pour télé apposée, vous ne pourrez plus l'enlever.

## Page 31

Enregistrez votre produit pour recevoir les éléments suivantes:

- \* Détails sur les nouvelles tendances - un aperçu sur les nouveautés
- \* Sondages - avoir une voix au sein de notre communauté
- \* Offres exclusives et codes promo
- \* Service de pièces de rechange rapide et facile

Pour enregistrer votre produit, visitez [ameriwoodhome.com](http://ameriwoodhome.com)

### 5 Étoiles

Visitez le site Web de votre détaillant local, évaluez votre produit acheté et laissez-nous quelques commentaires !

Nous tenons à offrir un grand "Merci" à tous nos clients pour avoir pris le temps d'assembler ce produit "Ameriwood Home", et de nous donner vos commentaires précieux.

Merci